



CONTACT US



L13 144 Edward Street,
Brisbane City, Qld 4000



www.chelion.com.au



1300 208 962

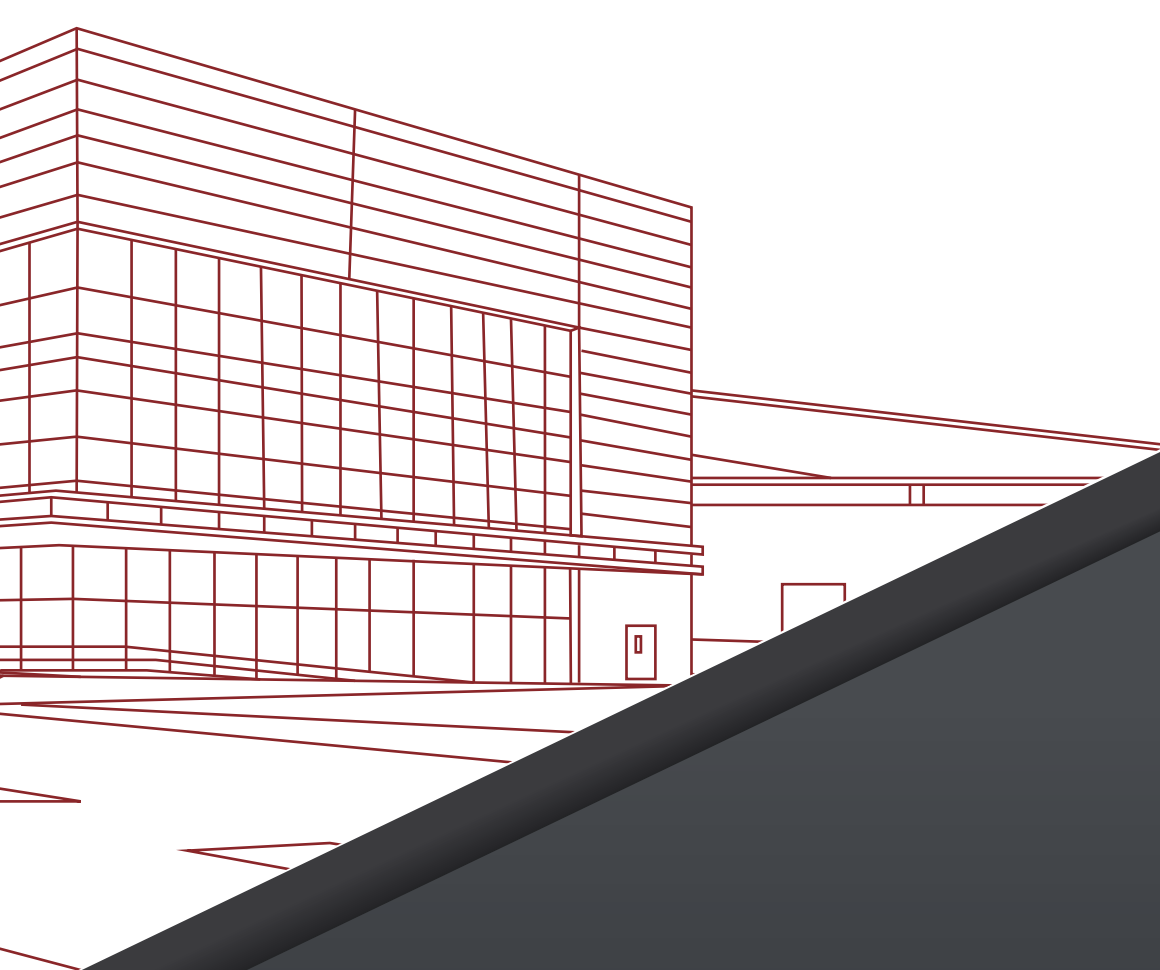

Maximum Safety for Your Energy

Matrix

C&I / Utility BESS Introduction

Peak Shifting

Spikes in power (for example when industrial machinery comes online) are often a major contributor to power bills across Commercial and Industrial businesses. Battery Energy Storage Systems (BESS) can store energy during low, or ‘valley’ time periods and discharge during these ‘peak’ periods.

This function has multiple benefits including limiting peak demand from the grid and can generate significant cost-savings by allowing businesses to change to Time of Use (TOU) tariffs or implement a power ‘ceiling,’ thereby reducing peak demand penalties.

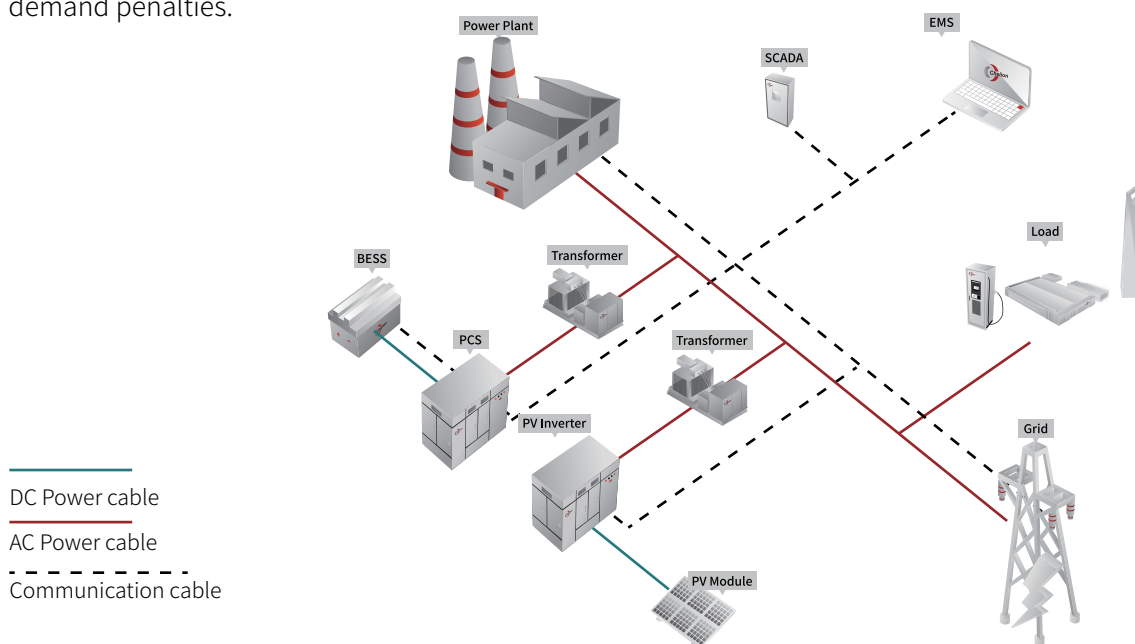

Application Scenarios

Utility power grids, commercial buildings, industrial parks and other large consumers of electricity

Values to Customers

Significant cost savings and ‘peak demand’ charge reduction. (C&I Customers)

Reduce operational cost (OPEX) of generating power during peak periods (Utilities)

Less frequent investment in infrastructure upgrades due to flatter loads with smaller peaks (Owner)

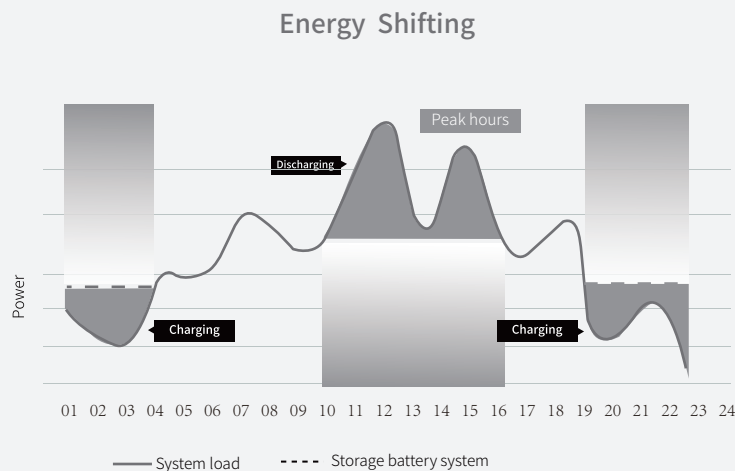

Frequency Control Grid Services

BESS have an extremely fast regulation rate with high accuracy and a ‘millisecond’ response time.

As fossil-fuel derived stable base-load is phased out, and the grid becomes more distributed, Battery Energy Storage Systems will be imperative to ensure that frequency regulating services can be provided when required, meeting the charge/discharge requirements imposed on assets and the wider grid network.

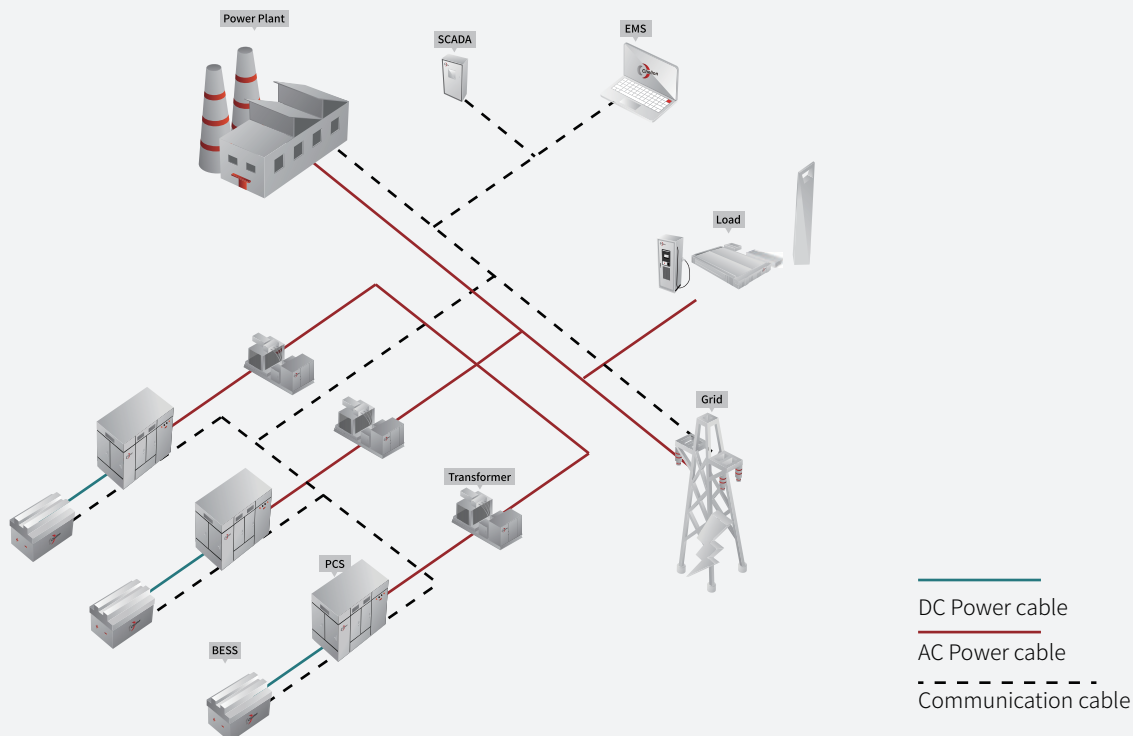

BESS installed in thermal power plants can improve the Automatic Generation Control (AGC) regulation performance of thermal power units to meet the frequency regulation requirements of power grids. BESS can also be used to improve the deep adjustment capability of thermal power units to ensure safe and stable operation.

Application Scenarios

Utility power grids, thermal power plants with insufficient frequency and peak regulation capacity

Values to Customers

Obtain greater benefit in the AGC market

Ensure system frequency stability via constant and reliable balance.

Reduce the investment of power generation, save costs and improve the life and performance of assets.

Sequence diagram

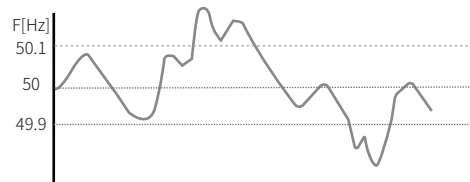

Charge battery from grid when the power abundant, Discharge battery to compensa power of grid and keep regular frequency.

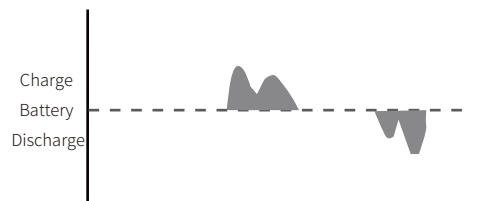

Renewable Integration



As wind and solar energy adoption continues to grow, power grids will be impacted by the intermittent nature of renewable sources. Incorporating a BESS is the most cost-effective method to safely and successfully integrate renewable energy. Similar to ‘peak shifting’ the spikes in power usage, A BESS assists in smoothing the variable power supply generation and allows electricity to flow regardless of time and weather conditions.

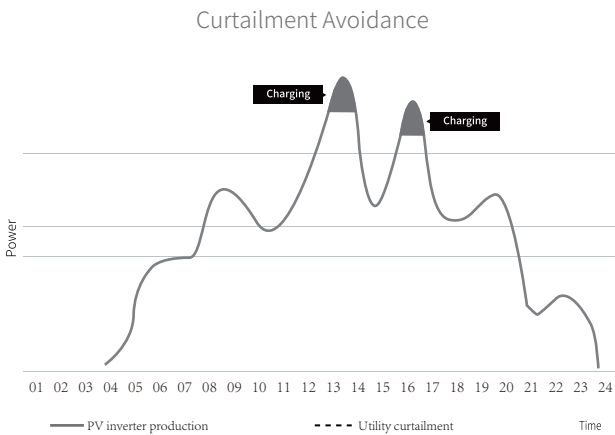
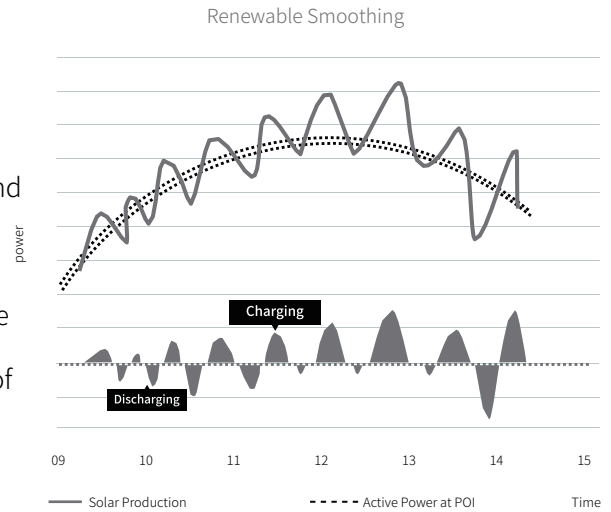

Production of renewable energy may be curtailed by a grid operator for various reasons, such as increasing the stability of the network during high production/low demand periods. During these periods of curtailment, a BESS allows this otherwise wasted ‘excess’ renewable energy to be stored and delivered when needed.

BESS are able to shift the power generation from the PV system as energy demand fluctuates. They can store ‘surplus’ PV energy during low-demand periods and discharge when needed, for a maximised Return on Investment (ROI).

Energy shifting allows investors to generate significantly greater revenues from a PV plant and enables higher DC/AC ratios for PV deployments as well as time-variable grid injection.

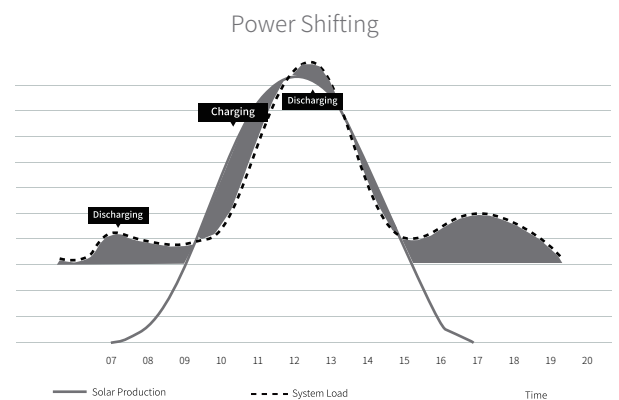

Integrating renewables brings more long-term reliability and resiliency to the grid, as the Battery Storage Systems can be used to manage short-term variability for voltage correction and frequency response services

Renewable Integration

PV arrays and other large renewable energy projects

Values to Customers

Realise renewable energy transition targets and reduce inefficiency

Reduce grid stress from the intermittent nature of renewable energy, expanding the renewable energy capacity percentage and reducing 'wasted energy'

Reduce grid investment for renewable energy connections

Increase the prediction accuracy of power stations, maintaining safety and stability of the grid

Application Scheme

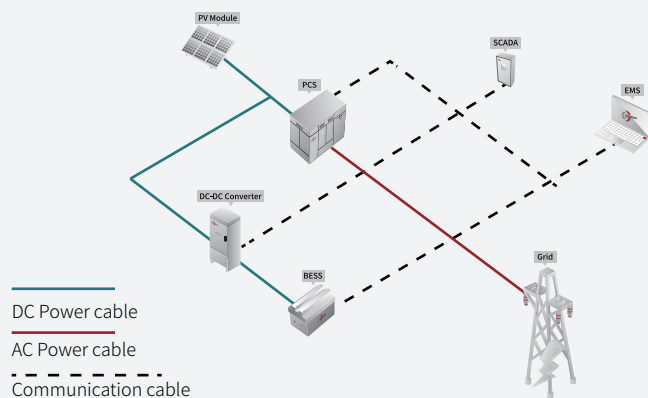

DC Coupled:
DC Coupled Batteries and PV modules share one inverter:
PV inverter with a direct connection to PV modules and connection via DC-DC converter to batteries.
→ lower CAPEX due to less equipment

AC-Coupled:
AC Coupled Batteries and PV modules have their own inverters and can either share one point of connection (POC) or have separate POCs (a standalone ESS).

→ more operational flexibility

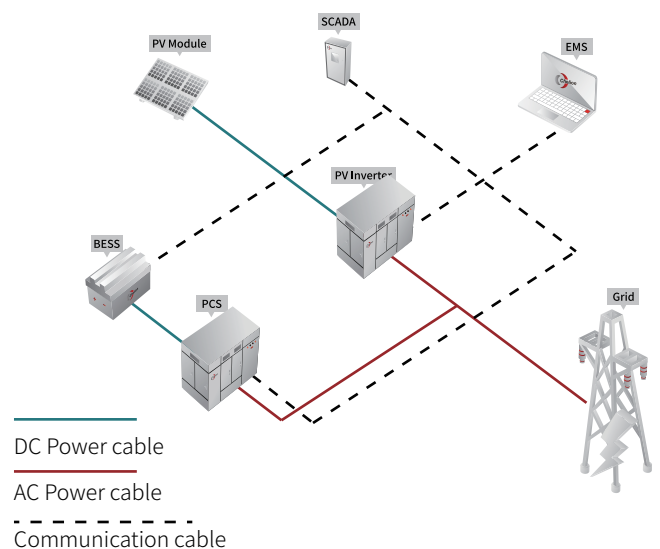

Microgrid



In a microgrid, using renewable energy and a BESS is the most redundant solution. When a BESS is used in a microgrid, it greatly increases the safety and stability of the entire system, especially with off-grid operations. In addition, more renewable energies (such as combined Solar, Wind and Hydro) can be integrated to reduce fossil fuel consumption, optimise the power supply structure and balance the grid.

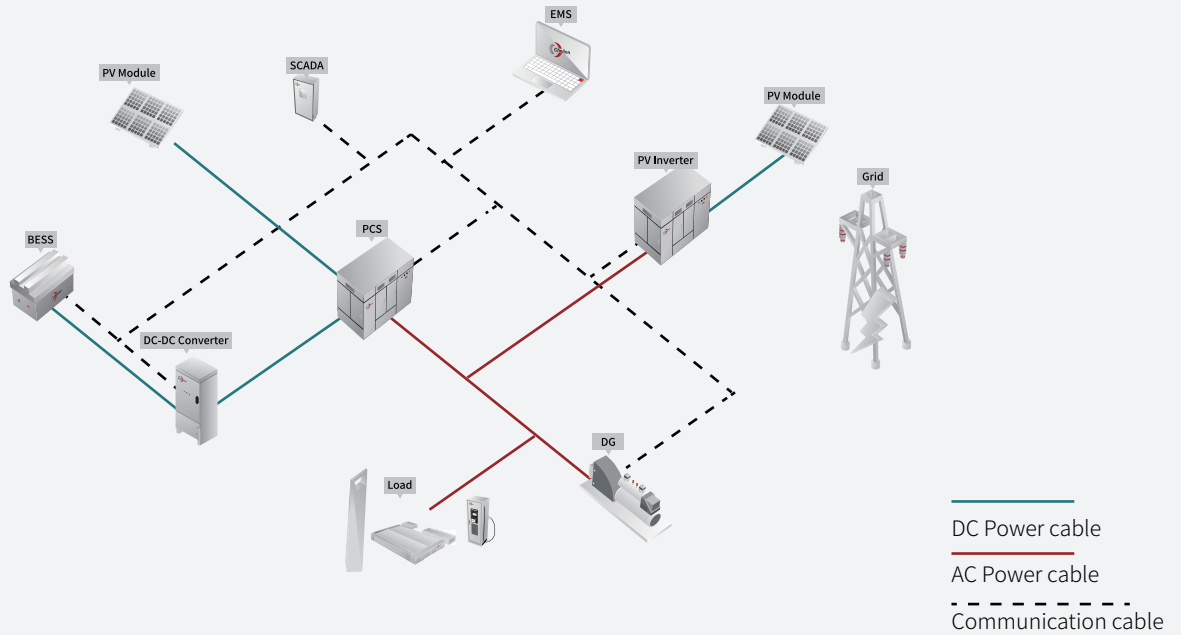

Application Scenarios

Business centers, communities, factories with multiple energy inputs and ‘islanded’ operations

Values to Customers

Reduce electricity bills and costs of diesel generation via self-consumption of renewables.

Allow diesel generators to be switched off when energy is being generated from renewables, reducing carbon footprint.

Improve power supply reliability and overcome grid outages more easily, whether planned or unplanned.

Green and sustainable source of energy

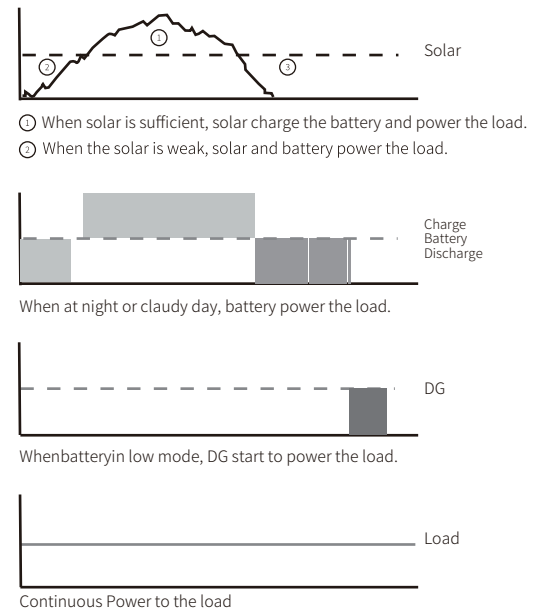

Backup or Off-Grid

BESS serves as an ideal backup for supplying power quickly and seamlessly, with the ability to switch to off-grid, or 'island' mode in a very short time (typically in the >6ms range) and serving as an uninterrupted power supply (UPS). The black start function of a BESS system can provide support to the grid in case of a widespread outage and improve power supply reliability.

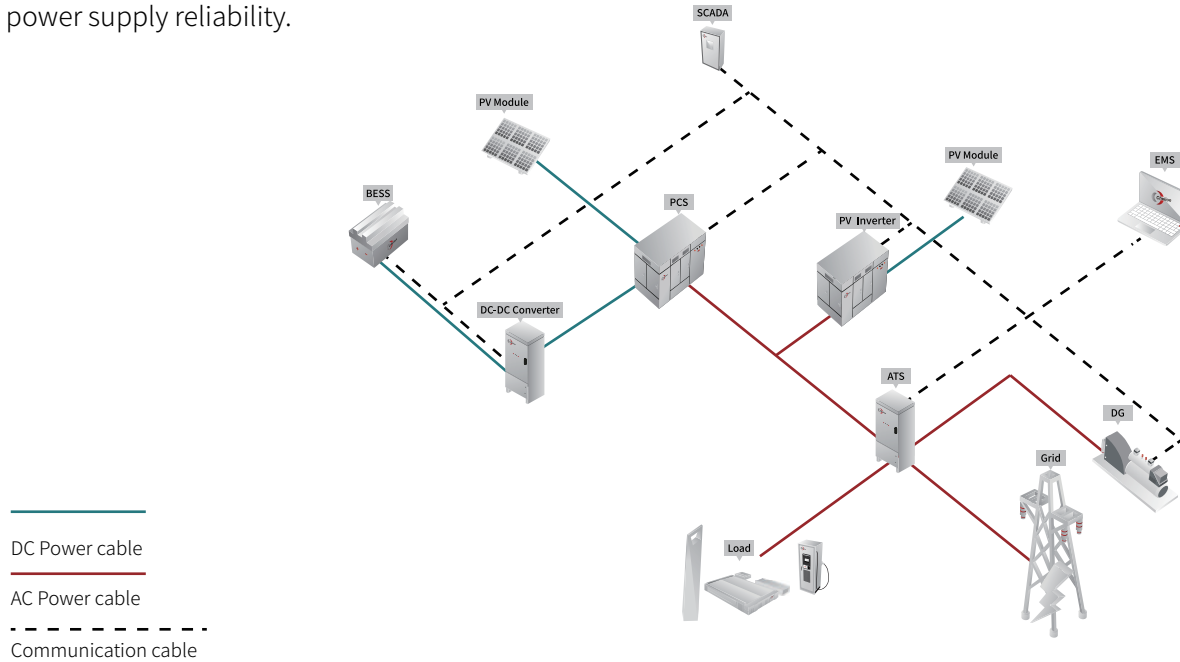

Application Scenarios

Utility power grids, critical loads, commercial buildings and industrial parks



- ① When solar is sufficient, solar charge the battery and power the load.
- ② When the solar is weak, solar and battery power the load.

Values to Customers

Backup energy, ensuring appliances and devices work uninterrupted and reduce economic loss associated with grid outages or disconnections. (Customers)

Black start capability, improving reliability of the grid (Utilities)



When at night or cloudy day, battery power the load.



When battery in low mode, DG start to power the load.



Continuous Power to the load

Product Features



High Level Integration

Lithium iron phosphate battery (LFP) integrates with BMS, PDU, FFS, cooling unit, etc.

Integrated battery rack provides a convenient system for indoor and outdoor application.

Advanced integration ensures optimal system performance and lower cost



Efficient and Flexible

Modular design supports convenient installation, parallel connections and easy system expansion.

Intelligent battery management system and cell-level temperature control ensure a high-level safety, efficiency, and a longer-lasting battery life cycle.

Applicable for a vast number of business models. For instance, solar self-consumption, managing consumption peaks, emergency backup power or providing stable energy in other special use case.



Safe and Reliable

Multi-level monitoring and management ensures battery safety.

DC electric circuit safety management includes fast response and anti-arc protection.

A three-level management system design delivers high reliability.



Smart and Friendly

Open battery interface ensures integration into any energy system.

Integrated local controller enables single-point communication interface.

Fast state monitoring and faults recording enable pre-alarm and fault location.

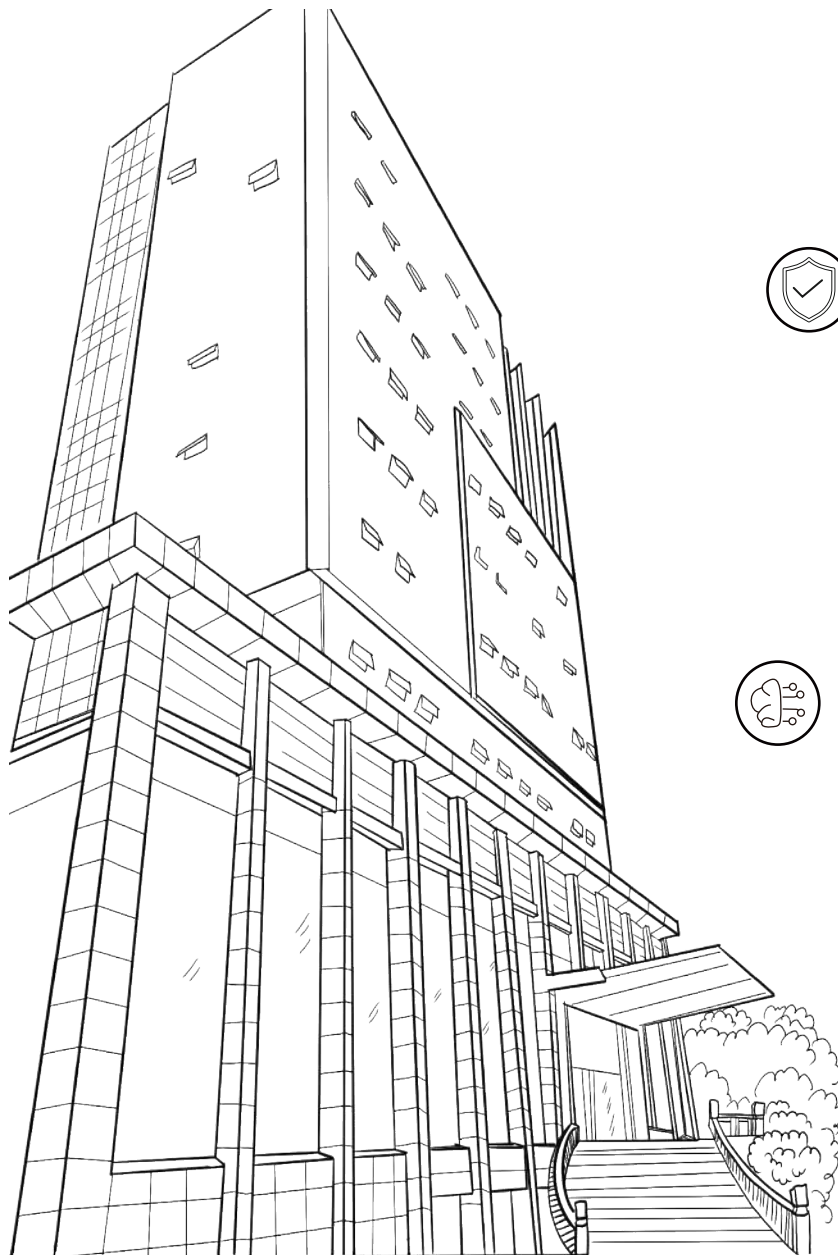

Matrix CP Series



	Matrix CP-X2	Matrix CP-H2	Matrix CP-M2A
Battery System Capacity	24.9kWh	42.62kWh	107.98kWh
Battery System Voltage	336V	576V	729.6V
Battery System Voltage Range	315~378V	531~648V	615.6~820.8V
Round-trip Efficiency	0.96(@0.5C)	0.96(@0.5C)	0.96(@0.5C)
Dimension (W*D*H mm)	600*505*1380(mm)	600*505*2130(mm)	803*845*2130(mm)
Weight	330kg	450kg	1228kg
Max charge/discharge Current	74A	74A	148A
Operating Temperature Range	0~50 °C	0~50 °C	10~40 °C
Humidity	5%~95% No condensing	5%~95% No condensing	5%~95% No condensing
Altitude	<2000m	<2000m	<2000m
Communication	Ethernet / RS485 / CAN	Ethernet / RS485 / CAN	Ethernet / RS485 / CAN
Enclosure Protection Rating	IP20	IP20	IP20
Battery Module Qty.(Optional)	2~10	5~12	1~19
Certification	IEC62619/VDE2510-50/UL1973/CE/CEC	IEC62619/UL1973/CE	IEC62619 / UN38.3 / UL1642 / UL1973 / JIS C 8715-2 / UL9540A / CE / IEC62477-1 / VDE-AR-E 2510-50:2017

PCS 30kW



30kW High power density



Bi-directional Power Conversion System



Grid-support functions



Droop control/communication control functions



DC coupled solution

Battery Side

Charging and Discharging voltage range	150V-750V(350V-750V @full load)
Rated Power	30kW
Maximum Power	33kW
Maximum Charging and Discharging Current	90A
Battery Switch-off Mode	Relay
Over Voltage Protection	Software Protection
Over Current Protection	Software Protection & DC Fuse

Bus Side

Rated Power	45kW
Input Voltage Range	700-830(V)
Maximum Input Current	32.5 A*2

AC Output

Rated Output Power	30kW
Maximum Apparent Power	33kVA
Rated Grid Voltage	3/N/PE, 400VAC
Power Factor	Listed: 0.8~1 leading or lagging Actual:0.1~1 leading or lagging
THDi	<3%
Overload Capacity(off grid)	110%~120%, 10 min 120%~150%, 200 ms
Peak Efficiency	97.3%
CEC Measured Efficiency	96.5%

General Specification

Dimension(W*H*D)	440*173*596(mm)
Cooling	Forced Air Cooling
Weight	33 kg
Topology	Non-isolation
Operation Altitude	4000m(>2000m derating)
Temperature	-30°C~60°C(>45°C derating)
Humidity	95%
Noise	≤65 dB
IP Rating	IP20

PCS(125kW, 250kW, 500kW)



Modular design and wide power range in single cabinet



Bi-directional Power Conversion System



Grid-support functions



Flexible derating available

Model	PWS1-500KTL-EX-8M	PWS1-500KTL-EX-4M	PWS1-500KTL-EX-2M
Batteryrange voltage	600~900V		
DC Max Current	873A	436A	218A
AC voltage	400Vac (3P3W)		
AC current	720A	360A	180A
AC max current	792A	396A	198A
Nominal power	500kVA	250kVA	125kVA
AC max power	550kVA	275kVA	137.5kVA
Short circuit current	960.3A@500ms	479.6A@500ms	198A@500ms
Off-grid short circuit current	1600A@80ms	800A@80ms	400A@80ms
Output THDU	<3%		
AC frequency	50/60Hz		
AC PF	Listed: 0.8~1 leading or lagging (Controllable) Actual: 0.1~1 leading or lagging (Controllable)		
Overload(off-grid)	105%~115% 10min; 115%~125% 1min; 125%~150% 200ms		

General Specification

Cooling	Forced air cooling		
Noise	70dB		
Enclosure	IP20		
Max elevation	3000m/10000feet (> 2000m/6500feet derating)		
Operating ambient temperature	-20°C to 50°C (De-rating over 45°C)		
Humidity	0~95% (No condensing)		
Size (W×H×D)	1100*2160*800mm		
Weight	600Kg	450Kg	300Kg
Installation	Floor standing		

Other

Peak efficiency	98.20%		
Protection	OTP, AC OVP/UVP, OFP/UFP, EPO, AC Phase Reverse, Fan/Relay Failure, OLP, GFDI, Anti-islanding		
Configurable protection limits	Upper/Lower AC Voltage/Frequency limit, Battery EOD voltage.		
AC connection	3-Phase 3-Wire		
Display	Touch Screen		
Communication	RS485,CAN,Ethernet		
Isolation	Non-isolation		

Matrix Ares Series



All In One design with a highly integrated ESS and a protective structural design for outdoor applications.



Modular design, highly adaptable to various application scenarios.



Modular design cabinets, highly adaptable to various application scenarios.



Three-level BMS structure guarantees highly efficient cooperation and safety performance



Separation of functions, independent compartments, low system maintenance costs

General Data

Dimension (W*H*D)	1112mm*1500mm*2250mm
Weight	2140kg
Enclosure Protection Rating	IP55
Anti-Corrosion	C3 (Optional upgrade to C5)
Operation Temperature Range	-30°C to +55°C
Humidity	5%-100%
Cooling Method	Forced Air Cooling
Fire Fighting System	Aerosol
Auxillary System Peak Power Requirement	4 kW

Battery Data

Rated Energy	163.84 kWh (10.24kWh*8/8)
Rated Voltage	409.6V
Operating Voltage	358.4-460.8V
Max. Operation Current	100 A
Max. Battery Module Qty / Rack.	8/8
Battery Cell Type	LFP 3.2V 100Ah
Battery Module Dimension(W*H*D)	445*129*913.2mm
Round-trip Efficiency(@0.5C)	95%

AC Output Data

Rated AC Power	30 kVA (Expandable to 2*30 kVA)
Rated AC Output Frequency	50 Hz
Isolation Method	Transformer less
Rated Grid Voltage	3P+N+PE, 400V AC
Peak Efficiency	97.3%

Matrix Zeus Series



All In One design with a highly integrated ESS and a protective structural design for outdoor applications.



Modular design, highly adaptable to various application scenarios.



Modular design cabinets, highly adaptable to various application scenarios.



Three-level BMS structure guarantees highly efficient cooperation and safety performance



Separation of functions, independent compartments, low system maintenance costs

General Data

Dimension (W*H*D)	1500 mm*1437 mm*2360 mm
Weight	3300kg
Enclosure Protection Rating	IP55
Anti-Corrosion	C3 (Optional upgrade to C5)
Operation Temperature Range	-30 °C to +55 °C
Humidity	5%-100%
Cooling Method	Liquid Cooling for Battery
Fire Fighting System	Aerosol
Auxillary System Peak Power Requirement	9 kW

Battery Data

Rated Energy	301 kWh (43kWh*7)
Rated Voltage	1075.2 V
Operating Voltage	840~1226.4V
Max. Operation Current	140 A
Max. Battery Module Qty / Rack.	7
Battery Cell Type	LFP 3.2V 280Ah
Battery Module Dimension(W*H*D)	820*245*1100 mm
Round-trip Efficiency(@0.5C)	95%

AC Output Data

Rated AC Power	100kVA
Rated AC Output Frequency	50Hz
Isolation Method	Transformer less
Rated Grid Voltage	3P+PE, 400VAC
Peak Efficiency	97.3%

Matrix UP Series





- 

Modular design with multiple power densities available. Suitable for all scenarios.
- 

Standardised container design and flexible capacity extension.
- 

Rack mounted or a container-based configuration
- 

Three-level battery management system design delivers high reliability
- 

Advanced integration ensures optimal system performance and lower costs
- 

Open battery interface ensures integration into any energy system

General Data

Rated Capacity	500kW/ 1079.8kWh
Rated Voltage of Battery	806V
Battery Voltage Range	680~907V
AC Output Voltage	400V, 3P+PE
Rated AC Output Frequency	50 Hz
System Charge/Discharge Rate	0.5C
Dimension (W*D*H)	6058*2462*2896(mm)
Weight	~15 Ton
Humidity	5%~95% (No condensing)
Ambient Temperature	-20 °C~50 °C
Altitude	<2000m
Enclosure Protection Rating	IP54
Battery Certification	IEC62619 / UN38.3 / CE / UL1642 / UL1973 / UL9540A / JIS C 8715-2
Communication	Ethernet / CAN / RS485
Cooling	HVAC

Matrix UE Series



Liquid cooling technology and a precise thermal design. The temperature difference between cells inside the battery cabinet is less than 3°C, increasing service life by up to 23%



Highly integrated and supports back-to-back installation. Saves up to 34% floor space



Three-level anti-leakage design, guaranteeing safe operations



Complete FSS, ensuring system safety



Liquid cooling technology reduces auxiliary consumption by up to 50%



Pre-installed design with no battery module handling on-site. Transportation and installation costs are reduced

General Data

Rated Energy	4073kWh
Rated Voltage	1331.2V
Voltage Range	1164.8V~1497.6V
Charging/Discharging Power (0.5P)	2036.73kW
Dimension (W*D*H)	6058*2438*2896(mm)
Weight	~36Ton
Operating Temperature Range	-25°C to +55°C
Humidity	<95% No condensing
Altitude	<2000 m
Noise	<92dB @ 1m
Enclosure Protection Rating	ISO 12944, C4
Certification	IEC 62477, IEC 62619, UL 1973, UL 9540A, UN3536
Communication	Ethernet / CAN / RS485
Cooling	Liquid: 50% Ethylene glycol aqueous solution
Auxiliary power supply	Voltage Range: 3AC+N+PE, 400V(±10%), 50/60Hz Maximum Power: 36.7kW@25°C@0.5P