



Energy Storage Inverter

User Manual

Foreword

Summaries

Thank you for choosing the energy storage system iHome series (hereinafter referred to as iHome)!

This document gives a description of the energy storage system iHome series, including the features, performance, appearance, structure, working principles, installation, operation and maintenance. etc.

Please save the manual after reading, in order to consult in the future.



NOTE

The figures in this manual are just for reference, for details please see the actual product.

Suitable Model

- iHome-INV3.6k-H1H01
- iHome-INV5k-H1H01
- iHome-INV6k-H1H01









NOTE

- 1、 The inverter has not been tested to AS/NZS 4777.2:2020 for multiple inverter combinations. External devices should be used in accordance with the requirements of AS/NZS 4777.1.
- 2、 For compliance with AS/NZS 4777.2:2020, please select from Australia A, B, C or New Zealand. Please contact your local grid operator on which region to select.
- 3、 The inverter couldn't be operated until a region setting has been selected. The commissioning process should require installer to select Region before the inverter begins to operate.
- 4、 The inverter is only compatible with lithium batteries for use.
- 5、 The RCD (TYPE B) unit must be installed for backup load.

Symbol Conventions

The manual quotes the safety symbols, these symbols used to prompt users to comply with safety matters during installation, operation and maintenance. Safety symbol meaning as follows.

Symbol	Description
	Alerts you to a high risk hazard that will, if not avoided, result in serious injury or death.
	Alerts you to a medium low risk hazard that could, if not avoided, result in moderate or minor injury.
	Alerts you to a low risk hazard that could, if not avoided, result in minor injury.
	Anti-static prompting.
	Be care electric shock prompting.
 TIP	Provides a tip that may help you solve a problem or save time.
 NOTE	Provides additional information to emphasize or supplement important points in the main text.

Contents

1 Safety Description.....	1
1.1 Safety Announcements.....	1
1.1.1 Use Announcements.....	1
1.1.2 Inverter Symbol Illustration.....	3
1.1.3 Protection for PV Array.....	4
1.1.4 ESD Protection.....	4
1.1.5 Grounding Requirements.....	4
1.1.6 Moisture-proof Protection.....	5
1.1.7 Safety Warning Label Setting.....	5
1.1.8 Electrical Connection.....	5
1.1.9 Measurement Under Operation.....	6
1.2 Requirements for Operator.....	6
1.3 Environment Requirements.....	6
2 Overview.....	8
2.1 Product Intro.....	8
2.1.1 Model Meaning.....	9
2.1.2 Working Mode.....	9
2.2 Appearance and Structure.....	10
2.2.1 Appearance.....	10
2.2.2 Size.....	10
2.2.3 LED Signals.....	10
2.2.4 Inverter Structure Layout Illustration.....	11
2.3 Application Scenarios.....	12
3 Installation.....	15

3.1 Installation Process.....	15
3.2 Installation Preparation	16
3.2.1 Tools.....	16
3.2.2 Installation Environment.....	17
3.2.3 Installation Space	17
3.3 Transportation and Unpacking	18
3.3.1 Transportation	18
3.3.2 Unpacking and Checking.....	18
3.4 Mechanical Installation	19
3.5 Electrical Connection	31
3.5.1 Components Requirement.....	31
3.5.2 External Grounding Connection	31
3.5.3 DC Input (PV) Connection	35
3.5.4 AC Output Connection.....	37
3.5.5 WIFI Connection.....	41
3.5.6 Communication Port Connection.....	42
3.6 Side Cover Plate Installation	50
3.7 Check the Installation.....	50
4 APP Operation.....	51
5 Startup and Shutdown	52
5.1 Startup	52
5.2 CEI Self-Check	54
5.3 Shutdown	57
5.4 Generation control function	57
6 Maintenance and Troubleshooting	58
6.1 Maintenance	58
6.2 Troubleshooting.....	59
7 Package, Transportation and Storage.....	67
7.1 Package	67

7.2 Transportation 67

7.3 Storage 67

A Technical Specifications 68

B Acronyms and Abbreviations 73

1 Safety Description

This chapter mainly introduces the safety announcements. Prior to performing any work on the device, please read the user manual carefully, follow the operation and installation instructions and observe all danger, warning and safety information.

1.1 Safety Announcements



Before operation, please read the announcements and operation instructions in this section carefully to avoid accident.

The promptings in the user manual, such as "Danger", "Warning", "Caution", etc. don't include all safety announcements. They are just only the supplement of safety announcements when operation.



Any device damage caused by violating the general safety operation requirements or safety standards of design, production, and usage will be out of Chelion's guarantee range.

1.1.1 Use Announcements



Don't touch terminals or conductors that connected with grid to avoid lethal risk!

 **DANGER**

There is no operational part inside the inverter. Please do not open the crust of the inverter by yourself, or it may cause electric shock. The inverter damage caused by illegal operation is out of the guarantee range.

 **DANGER**

Damaged device or device fault may cause electric shock or fire!

- Before operation, please check if the inverter is damaged or has other danger.
 - Check if the external device or circuit connection is safe.
-

 **DANGER**

Before checking or maintenance, if the DC side and AC side is power down just now, it is necessary to wait for 5 minutes to ensure the inner device is completely discharged, and then the operation can be performed.

 **DANGER**

The surface temperature of the inverter may reach to 60°C. During running, please don't touch the surface to avoid scald.

 **CAUTION**







No liquid or other objects are allowed to enter the inverter, or, it may cause energy storage system iHome series damage.

 **CAUTION**

In case fire, please use dry power fire extinguisher. If using liquid fire extinguisher, it may cause electric shock.

1.1.2 Inverter Symbol Illustration

Table1-1 Inverter symbol illustration

Symbol	Illustration
	<p>Beware of a danger zone</p> <p>This symbol indicates that the product must be additionally grounded if additional grounding or equipotential bonding is required at the installation site.</p>
	<p>Beware of electrical voltage</p> <p>The product operates at high voltages.</p>
	<p>WEEE designation</p> <p>Do not dispose of the product together with the household waste but in accordance with the disposal regulations for electronic waste applicable at the installation site.</p>
	<p>Observe the documentation.</p>
	<p>CE marking</p> <p>The product complies with the requirements of the applicable EU directives.</p>
	<p>Danger to life due to high voltages in the inverter, observe a waiting time of 5 minutes.</p> <p>High voltages that can cause lethal electric shocks are present in the live components of the inverter.</p> <p>Prior to performing any work on the inverter, disconnect it from all voltage sources as described in this document.</p>
	<p>Beware of hot surface</p> <p>The product can get hot during operation.</p>

1.1.3 Protection for PV Array

When install PV array in daytime, it necessary to cover the PV array by light-proof material, or the PV array will generate high voltage under sunshine. If touching PV array accidentally, it may cause electric shock or human injury!



There exists dangerous voltage between the positive and negative of PV array!

When installing the device, make sure that the connection between inverter and PV array has been disconnected completely. And set warning mark in the disconnected position to avoid reconnecting.

1.1.4 ESD Protection



To prevent human electrostatic damaging sensitive components (such as circuit board), make sure that you wear a anti-static wrist strap before touching sensitive components, and the other end is well grounded.

1.1.5 Grounding Requirements



High leakage risk! The inverter must be grounded before wiring. The grounding terminal must be connected to ground, or, there will be the risk of electric shock when touching the inverter.

- When installing, the inverter must be grounded first. When dismantling, the grounding wire must be removed at last.
- Don't damage the grounding conductor.
- The device must be connected to protection grounding permanently.
- Before operation, check the electrical connection to ensure the inverter is grounded reliably.

1.1.6 Moisture-proof Protection



Moisture incursion may cause the inverter damage!

Observe the following items to ensure the inverter works normally.

- When the air humidity is more than 95%, don't open the door of the inverter.
- In the wet or damp weather, don't open the door of the inverter to maintain or repair.

1.1.7 Safety Warning Label Setting

In order to avoid accident for unwanted person gets close to the inverter or makes improper operation, observe the following requirements while installing, maintaining or repairing.

- Set warning marks where the switches are to avoid switching them on improperly.
- Set warning signs or safety warning belt in the operation area, which is to avoid human injury or device damage.
- When the port of battery pack and inverter are not in use, please don't remove the corresponding waterproof cover.

1.1.8 Electrical Connection

Electrical connection must be performed according to the description in the user manual and the electrical schematic diagram.



The configuration of PV string, grid level, grid frequency, etc. must meet the technical requirements of inverter.

Grid-tied generation should be allowed by the local power supply department and the related operation should be performed by professionals.

All electrical connection must meet the related country and district standard.

1.1.9 Measurement Under Operation

 CAUTION

There exists high voltage in the device. If touching device accidentally, it may cause electric shock. So, when perform measurement under operation, it must take protection measure (such as wear insulated gloves, etc.)

The measuring device must meet the following requirements:

- The range and operation requirements of measuring device meets the site requirements.
- The connections for measuring device should be correct and standard to avoid arcing.

1.2 Requirements for Operator

 CAUTION

The operation and wiring for energy storage system iHome series should be performed by qualified person, which is to ensure that the electrical connection meets the related standards.

The professional technician must meet the following requirements:

- Be trained strictly and understand all safety announcements and master correct operations.
- Fully familiar with the structure and working principle of the whole system.
- Know well about the related standards of local country and district.

1.3 Environment Requirements

 CAUTION

Avoid the energy storage system iHome series suffering directly sunshine, rain or snow to prolong the service life (detail please see 3.2.2 Installation Environment). If the installation environment does not meet the requirement, the guarantee time may be influenced.

The used environment may influence the service life and reliability of the energy storage system iHome series. So, please avoid using the inverter in the following environment for a long time.

- The place where beyond the specification (operating temperature:-25°C~60°C, relative humidity: 0%-95%).
- The place where has vibration or easy impacted.
- The place where has dust, corrosive material, salty or flammable gas.
- The place where without good ventilation or closed.

2 Overview

This chapter mainly introduces the device features, appearance, operating mode, etc.

2.1 Product Intro

With energy storage system iHome series, it is possible to effectively manage energy in users' home day and night. This energy storage system will provide a complete energy solution with multiple working modes which meet different application scenarios. It will bring independence and economy for energy use.

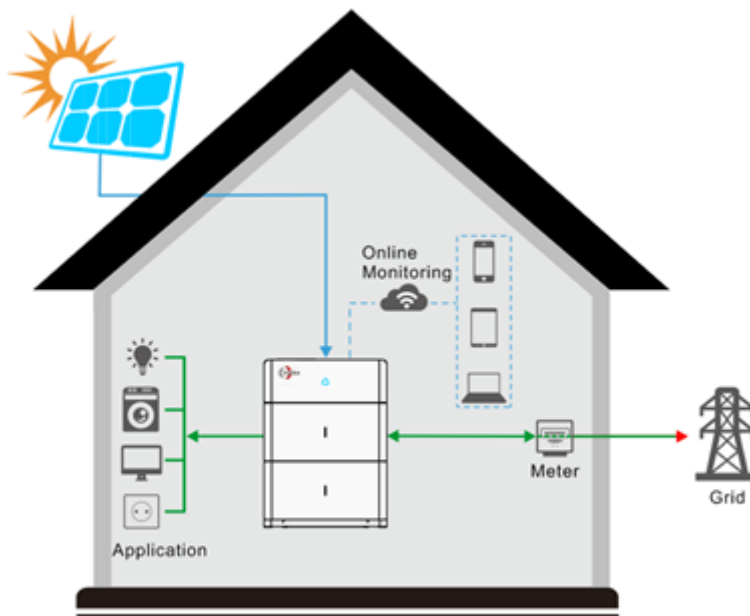

Figure2-1 Energy storage system

2.1.1 Model Meaning

Inverter

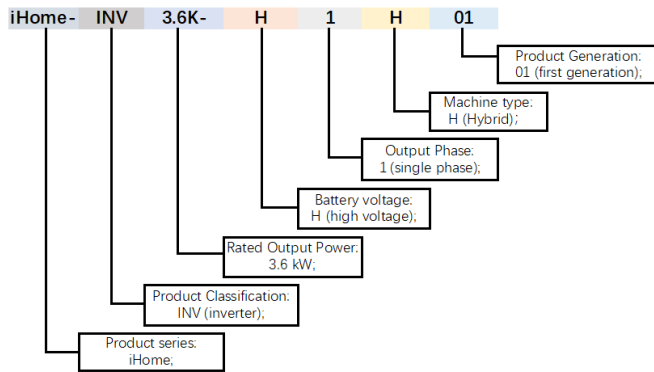

Figure2-2 Model meaning of inverter

2.1.2 Working Mode

Backup mode

iHome product can work as an energy backup unit in order to provide uninterrupted blackout protection when the grid goes down.

Time of use mode

iHome product can meet the maximum energy utilization rate and users' income. According to peak-valley electricity price and users' electricity demand.

Energy scheduling mode

iHome product provides charge and discharge time settings for customers, so they can pre-charge when the price of power is low, and save the energy for use when grid power prices are high.

External control mode

iHome product can realize the remote scheduling of inverter control, and energy management optimization strategy through API interface.

Peakload shifting mode

iHome product provides max. grid percentage setting for customers, so when the load is suddenly added and the power of grid port exceeds the maximum setting value, the iHome product will be in standby status.

Off-grid mode

iHome product can be operated in a completely off-grid mode where no grid power is available.



NOTE

The above modes are only functional definitions, and the setting items may not have corresponding items.

2.2 Appearance and Structure

2.2.1 Appearance

The appearance of the inverter as shown in Figure2-3.

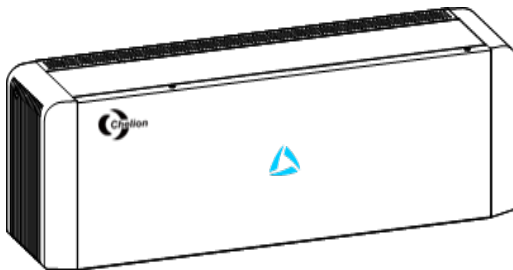

Figure2-3 Appearance of the inverter

2.2.2 Size





Figure2-1 Inverter size (Unit: mm)

2.2.3 LED Signals

Inverter

Table2-1 Illustration of the inverter LED

LED display	Status	Illustration
	Off	Inverter power off.

LED display	Status	Illustration
	Red	ON: inverter fault.
	Blue	ON: the system works normally.
		Flicker 1s: inverter alarm.
		Flicker 3s: inverter standby.

2.2.4 Inverter Structure Layout Illustration

The external terminals and switch of inverter as shown in Figure2-2.

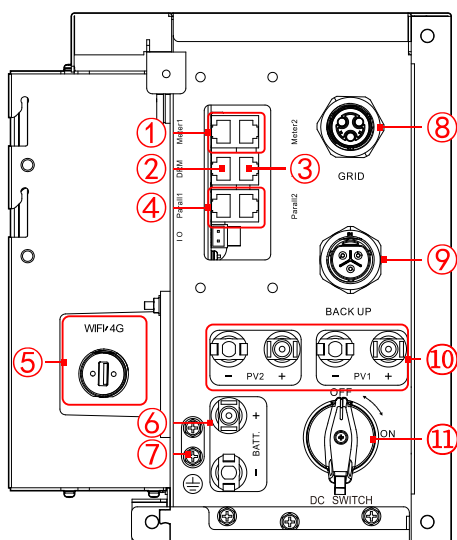



Figure2-2 Inverter structure layout diagram

Table2-2 Inverter terminals illustration

NO.	Mark	Illustration	Remarks
①	Meter1/ Meter2	Monitor grid side power.	Meter1 and Meter 2 are the same portal.
②	DRM	Inverter demand response modes.	\
③	BMS	Connect to COM port of battery to communicate with battery.	If installed battery
④	Parall1/Parall2	Have parallel function.	Reserved
⑤	WIFI/4G	It is used for WIFI/4G	\

NO.	Mark	Illustration	Remarks			
		communication.				
⑥	BATT.	<table border="1"> <tr> <td>+</td> </tr> <tr> <td>-</td> </tr> </table>	+	-	DC input terminal	It is used to connect with battery.
+						
-						
⑦		Grounding port	External grounding port.			
⑧	GRID	AC output terminal	It is used to connect with grid.			
⑨	BACKUP	AC output terminal	It is used to connect with load.			
⑩	PV1/PV2	<table border="1"> <tr> <td>+</td> </tr> <tr> <td>-</td> </tr> </table>	+	-	DC input terminal	It is used to connect with PV.
+						
-						
⑪	DC switch	DC switch	Can be removed under specific market requirements.			

DC switch

DC switch (as shown in the ⑪ of Figure2-2) is the connection switch between inverter and PV array.

- During installation and wiring, the DC switch must be OFF.
- Before maintenance, the DC switch must be OFF, and 5 minutes after the indicator is off, the maintenance can be done.



When maintenance or wiring, the DC switch must be disconnected.

2.3 Application Scenarios

The energy storage system iHome series can be applied in DC-coupled system, AC-coupled system and fully off-grid system, as shown in Figure2-3, Figure2-4 and Figure2-5.

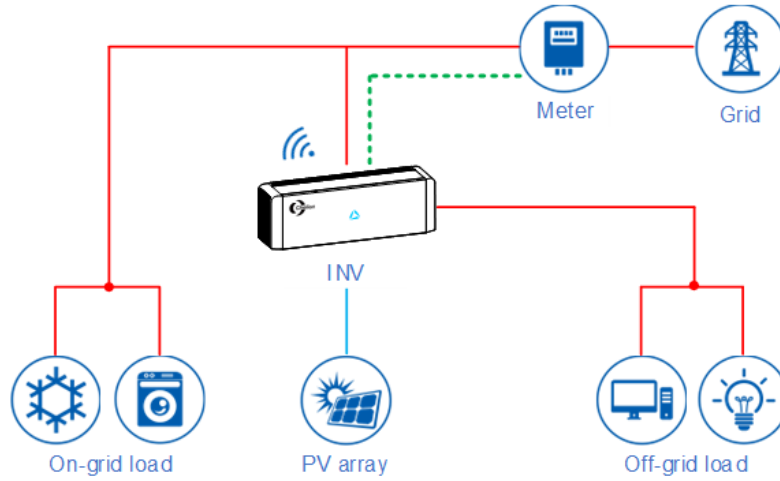

Figure2-3 DC-coupled system

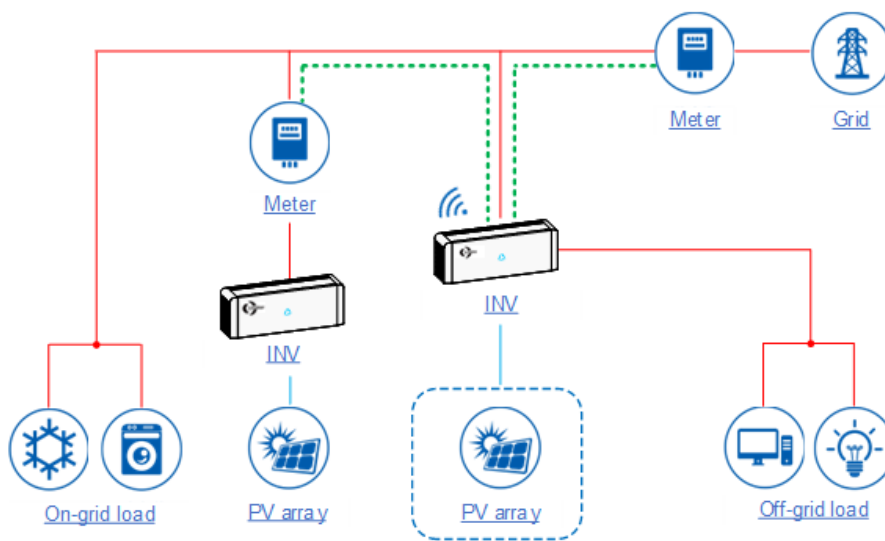

Figure2-4 AC-coupled system

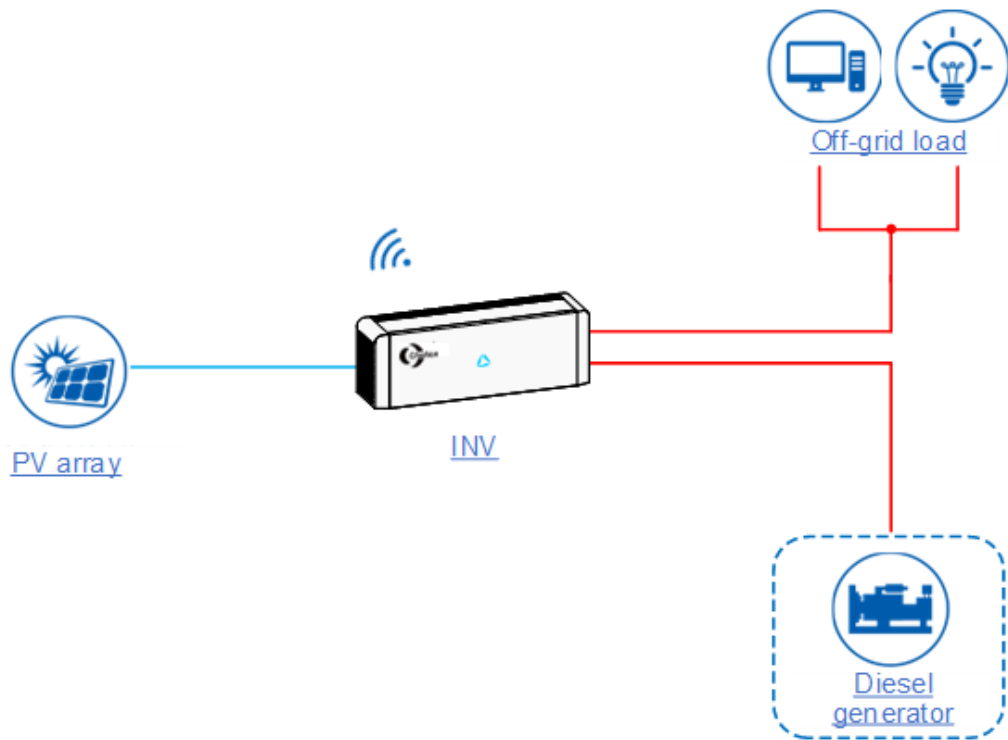

Figure2-5 Fully off-grid system

3 Installation

This chapter introduces the installation of the device, including installation process, installation preparation, transportation and unpacking, installation procedure, electrical connection and checking, etc.

3.1 Installation Process

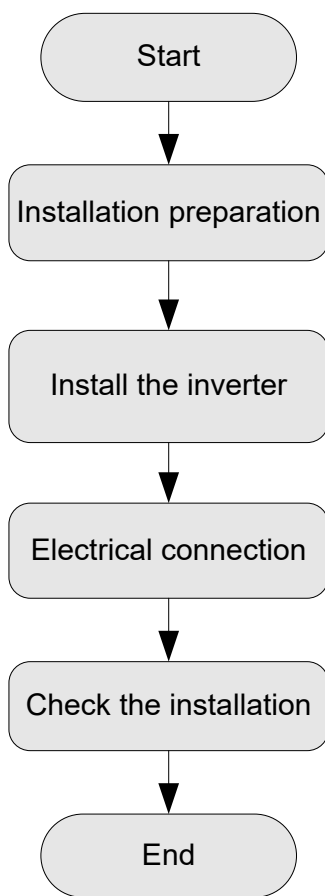

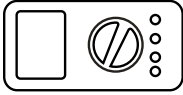

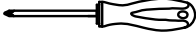

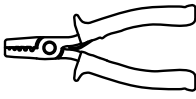
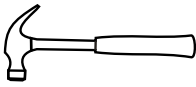
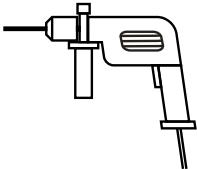
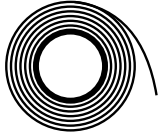
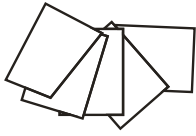
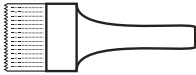
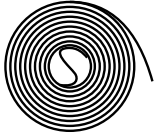
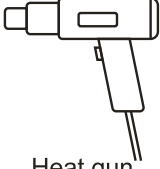

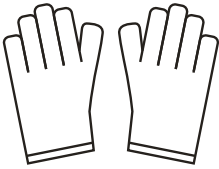
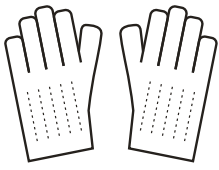
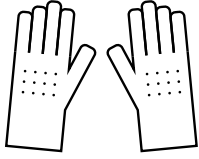

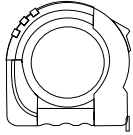





Figure3-1 Installation process

3.2 Installation Preparation

3.2.1 Tools

Tools			
			
Clamp meter	Multi-meter	Label paper	Phillips screwdriver
			
COAX crimping tool	Diagonal pliers	Wire stripper	Claw hammer
			
Hammer drill	Insulation tape	Cotton cloth	Brush
			
Heat shrink tubing	Heat gun	Electrician's knife	Protective gloves
			
ESD gloves	Insulated gloves	Hydraulic pliers	Cable tie
			
Tape	Levelling instrument	Goggles	Torque wrench

! CAUTION

The installation tools must be insulated to avoid electric shock.

When installing, please wear safety gloves and safety shoes.

When installing, please wear safety goggles and a dust mask to prevent dust from entering your eyes.

3.2.2 Installation Environment

- Do not install the iHome product in the place with poor ventilation.
- Do not install the iHome product in the place where has flammable or explosive materials.
- Ensure that there has sufficient fresh-air supply around the iHome product.
- The iHome product must be installed on the wall or supporter with enough bearing capacity.

NOTE

1. The iHome product is rated at IP65 for outdoor and indoor installation. But if the iHome product is installed under directly sunshine, its temperature will rise quickly, so, do not install the iHome product under directly sunshine.
2. It is suggested to install the iHome product under shade as shown in Figure3-2 to max the iHome product lifespan and efficiency.
3. For easy viewing and operating the iHome product please consider the visibility of the indicators during installation.

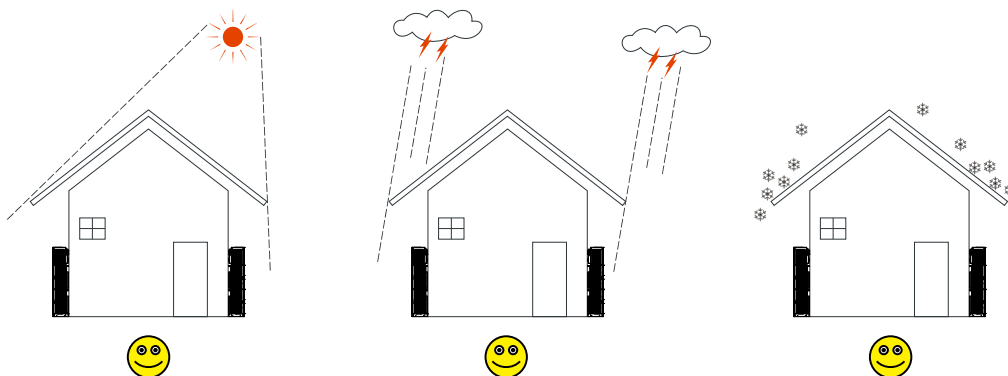

Figure3-2 Recommended installation environment

3.2.3 Installation Space

Keep at least 500mm from the left and right side of the device to other objects, keep at least 300mm from the top of the device to ceiling and keep at least 300mm from front of the device to other objects, which is good for heat dissipation, as shown in Figure3-3.

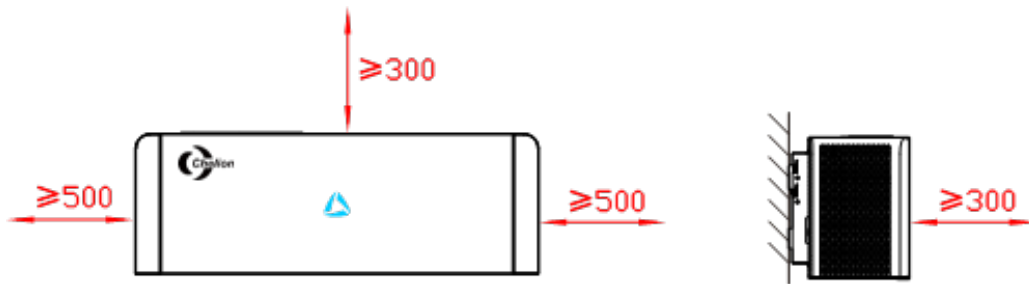

Figure3-3 Installation space (unit: mm)

3.3 Transportation and Unpacking

3.3.1 Transportation

The device should be transported by trained professional.



During transporting, please take care and avoid impacting or dropping.

3.3.2 Unpacking and Checking

NOTE

Select the unpacking site in advance. In principle, the unpacking site should be as close to the installation site as possible.

The device has been tested and checked strictly, but it still may be damaged during transporting, so, please check it carefully.

- Inspect the device's appearance, if any shipping damage is found, report it to the carrier and your local dealer immediately.
- Check if the types of the accessories are complete and correct. If there is any discrepancy, take notes and contact Chelion company or local office immediately.

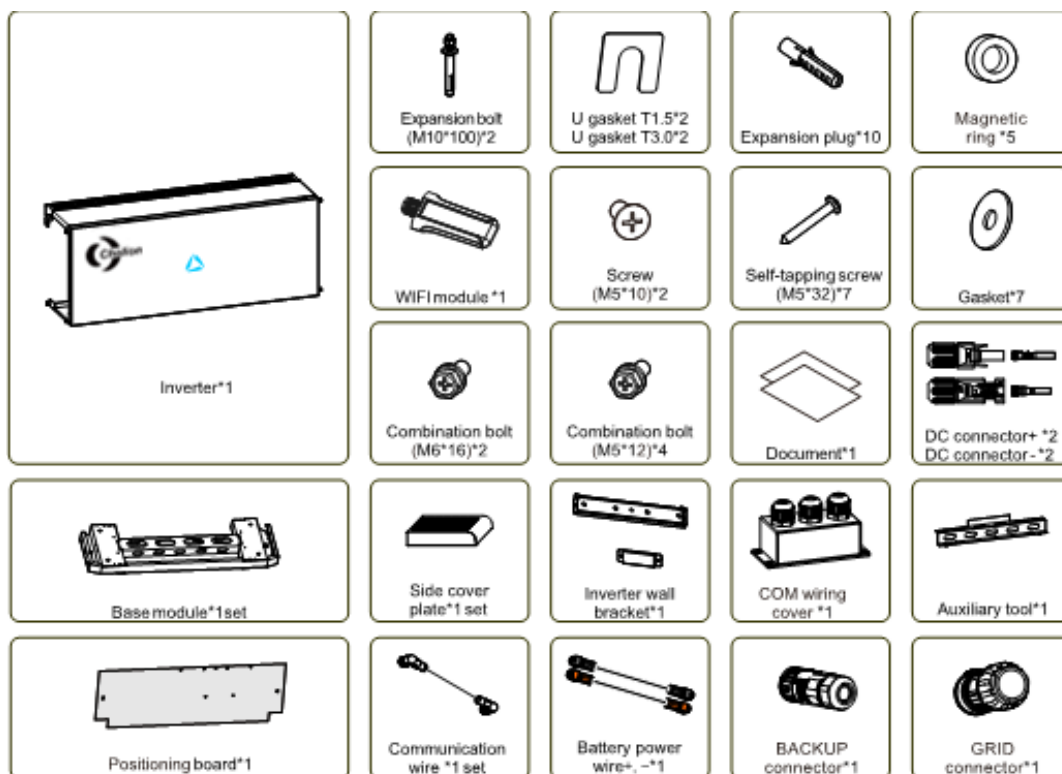

Figure3-4 Inverter packing list

NOTE

Smart meter is optional, they are provided according to the contract.

CAUTION

If the energy storage system iHome series needs to be stored for a long time after unpacking, it is necessary to pack the device by original package and save properly.

3.4 Mechanical Installation

CAUTION

Keep the installed place far away from the tube of water, electricity or gas, which is to avoid affect the installation.



When installing, please wear safety gloves and safety shoes.

Step 1 Mark the positions of the drill holes with the inverter positioning board.

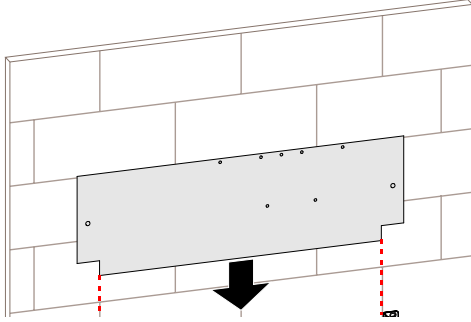

Figure3-5 Place inverter positioning board

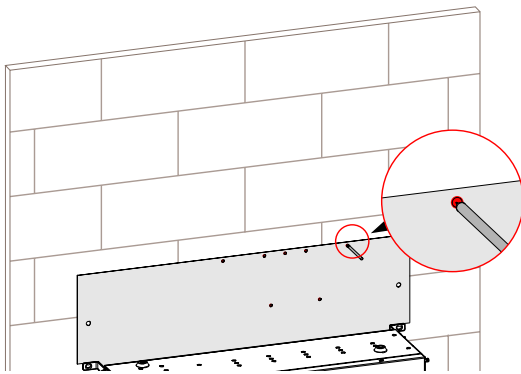

Figure3-6 Mark the inverter drilling position

Step 2 Drill seven holes on the wall with drill $\Phi 8$ (the depth of the hole range is 40~45mm), insert seven expansion plugs (8*40) into the drill holes.

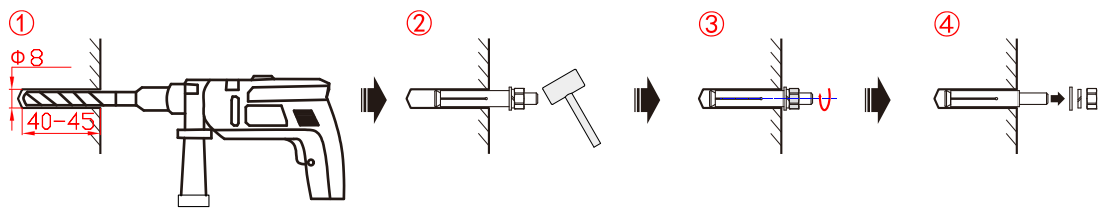

Figure3-7 Insert the expansion plugs (unit: mm)

Step 3 Attach the wall bracket to the wall using seven M5 Self-tapping screws with the tool of screwdriver, as shown in Figure3-8.

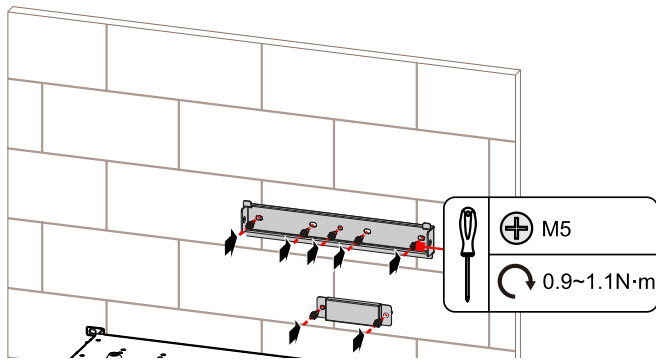

Figure3-8 Install inverter wall bracket

Step 4 Hang the inverter to wall-mounted bracket and tighten the wall bracket and the inverter with screw M6.

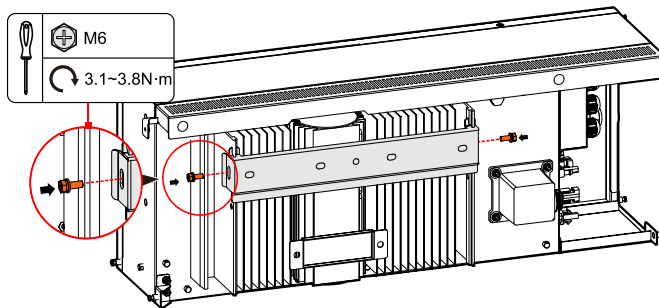

Figure3-9 Tighten the inverter

---End

3.4.2 Mechanical Installation for battery + inverter (optional as inverter can be used without battery)

NOTE

This section is optional as inverter can be used with just PV energy source without battery

Step 1 Determine the installation place.

1. Install auxiliary tool.

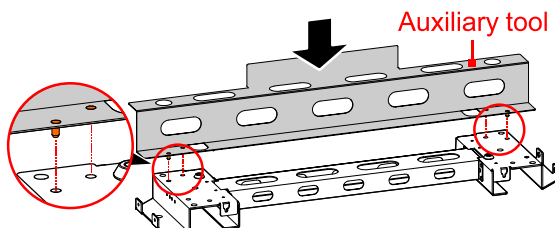

Figure3-10 Install auxiliary tool

2. Push the auxiliary tool against the wall

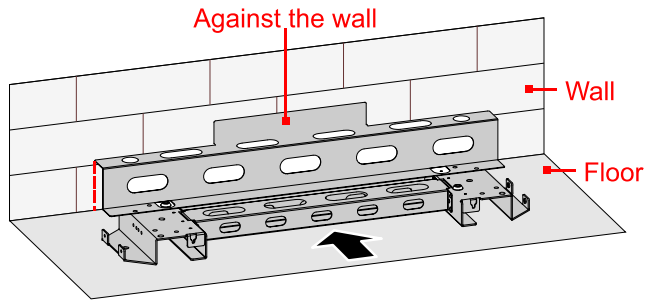

Figure3-11 Auxiliary tool against the wall

- Step 2 Mark the mounting holes of base module and battery packs.

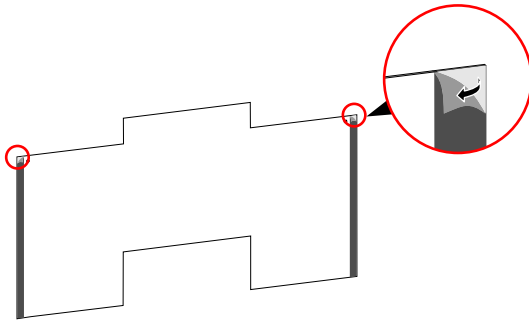

Figure3-12 Tear back glue

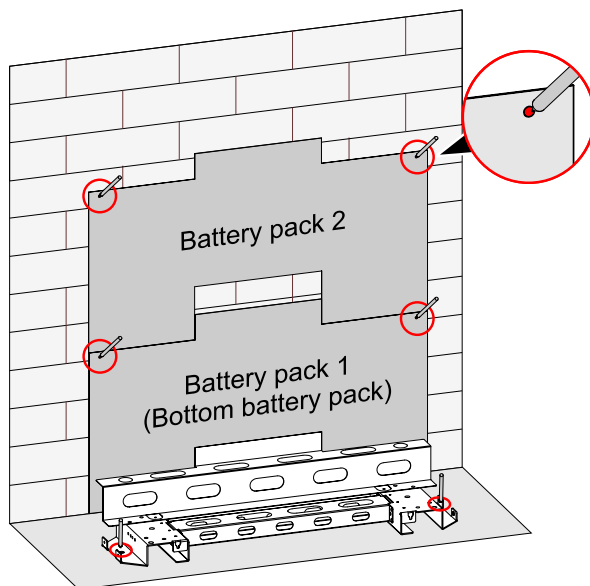

Figure3-13 Mark the installation holes

- Step 3 Remove the position boards and auxiliary tool.

Step 4 Drill four holes on the wall and drill two holes in the floor, for detail specification please see blow Table 3-1:

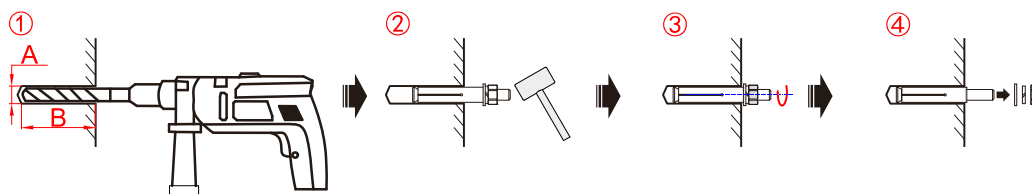

Figure3-14 Install the expansion bolt

Table3-1 Expansion bolt specification

Item	Base module	Battery pack
Expansion bolt	M10	M6
A	Φ 12.5mm	Φ 8mm
B	75mm~80mm	40mm~45mm

CAUTION

During drilling, please ware safety goggles and a dust mask to prevent dust from entering your eyes. After drilling, please clean the scrap in the installation holes, and then perform the installation.

CAUTION

Ensure that the installed floor is flat and horizontal. If not, please use gasket to make the floor horizontal. Ensure that the installed wall is flat and horizontal (flatness within 4mm) and the installed floor horizontal angle is 0°. If not, please use gasket to make the floor horizontal.

Keep the installed place far away from the tube of water, electricity or gas, which is to avoid affect the installation.

After drilling, please clean the scrap in the installation holes, and then perform the installation.

Step 5 Fix the base module to the installed floor, as shown in Figure3-15.

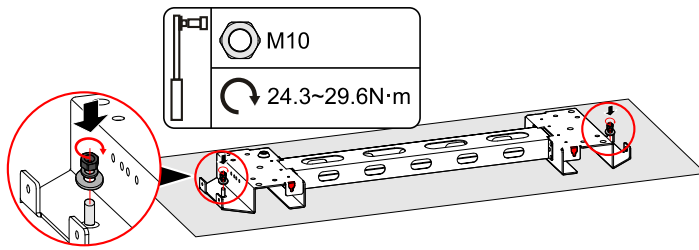

Figure3-15 Fix the base module

Step 6 Lead the cover plate into the base module and fix it with screws, as shown in Figure3-16, Figure3-17.

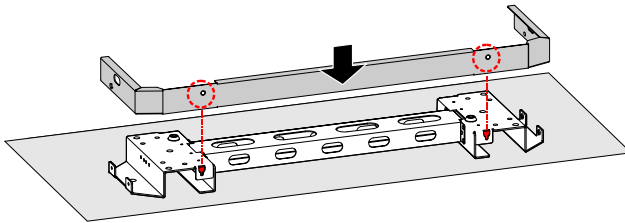

Figure3-16 Install the cover plate

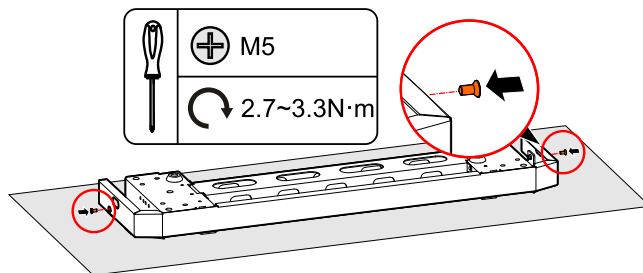

Figure3-17 Fasten the cover plate

NOTE

If the device is installed on the low-lying position and may have the risk of soaking by rain, we suggest to select the support to lift the device to avoid damage for the device. The installation of support is as follows.

1. Mark the installation holes, as shown in Figure3-18.

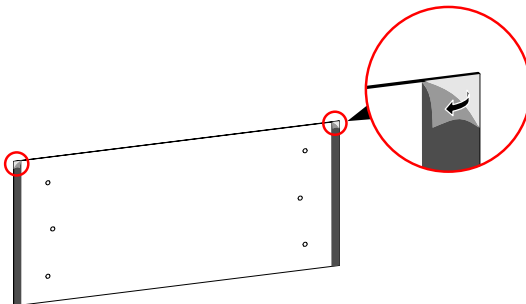

Figure3-18 Tear back glue

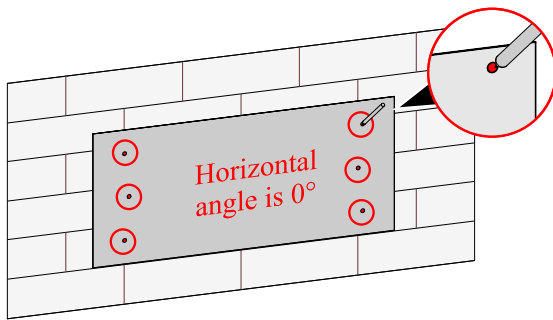

Figure3-19 Mark the installation holes

2. Install the expansion bolts, as shown in Figure3-20.

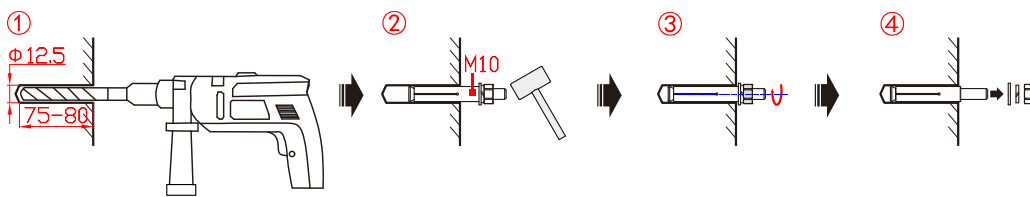

Figure3-20 Install the expansion bolt (unit: mm)

3. Fix the assembled base by expansion bolt M10, as shown in Figure3-21.

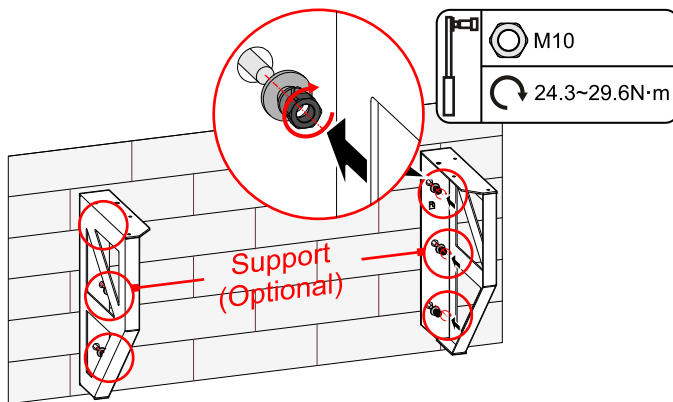

Figure3-21 Mark the installation holes

4. Assemble the support and base by screws M5, as shown in Figure3-22.

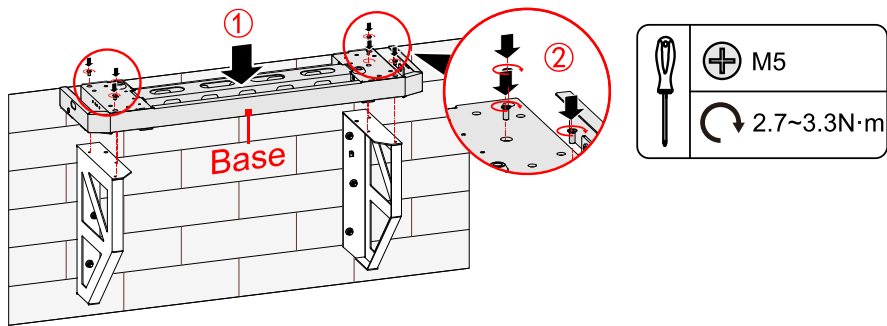

Figure3-22 Assemble the support and base

CAUTION

During drilling, please wear safety goggles and a dust mask to prevent dust from entering your eyes.

After drilling, please clean the scrap in the installation holes, and then perform the installation.

NOTE

The installation holes of base with support is the same as that of standard configured base, in above figure, we take standard configured base as an example to illustrate.

Step 7 Install battery packs.

1. Fix the bottom battery pack with base by wall bracket b, as shown in Figure3-23.

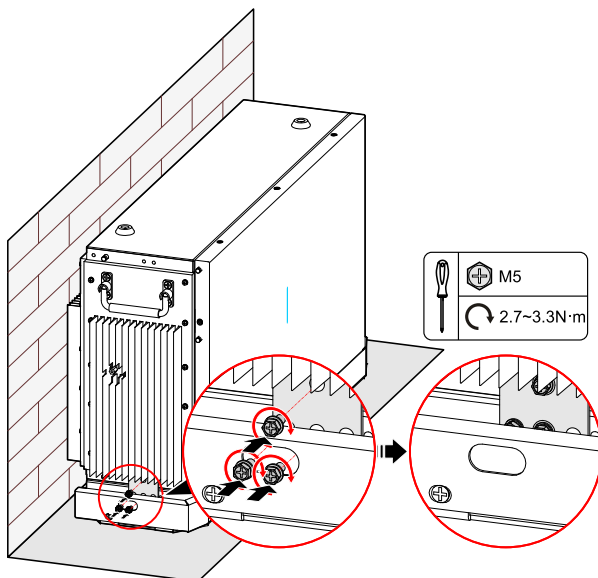

Figure3-23 Fix the bottom battery pack with base

2. Fix the wall bracket a of bottom battery pack1, as shown in Figure3-24.

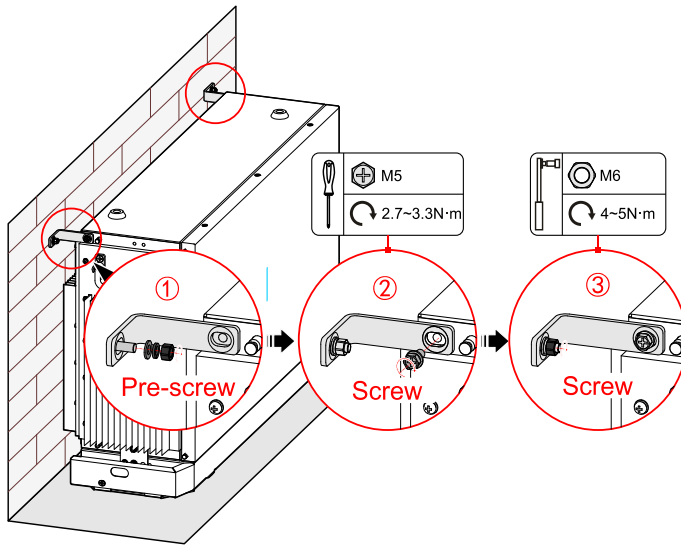

Figure3-24 Fix the wall bracket a

3. Place the battery against the wall, the bottom limit holes of the upper battery pack should match the screw on the top of the below battery pack, as shown in Figure3-25.

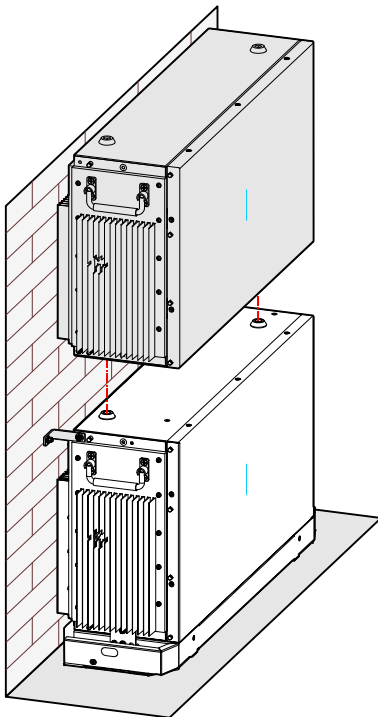

Figure3-25 Place the battery pack

4. Tighten the battery rack1 and the battery pack with screws.

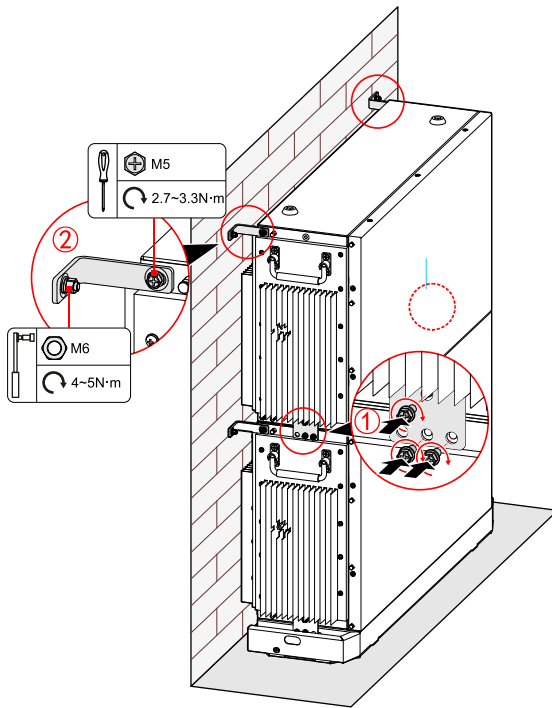

Figure3-26 Tighten the top battery pack

Step 8 Install the inverter.

1. Mark the positions of the drill holes with the inverter positioning board.

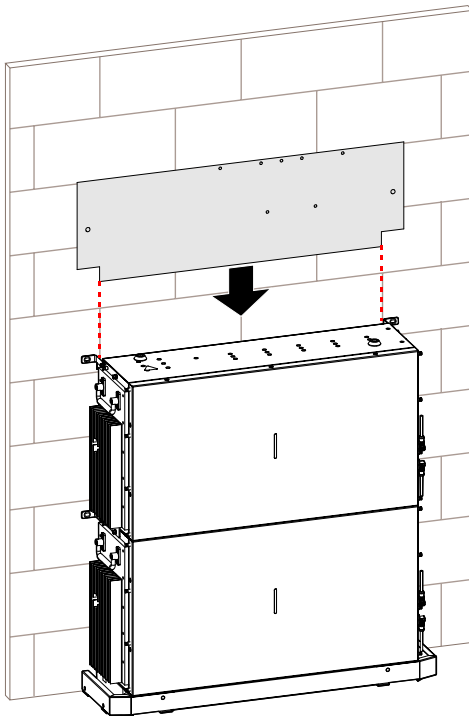

Figure3-27 Place inverter positioning board

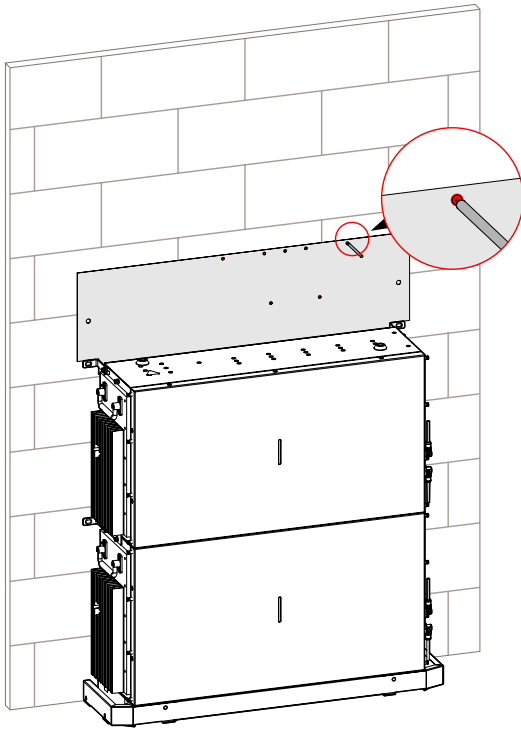

Figure3-28 Mark the inverter drilling position

2. Drill seven holes on the wall with drill $\Phi 8$ (the depth of the hole range is 40~45mm), insert seven expansion plugs (8*40) into the drill holes.

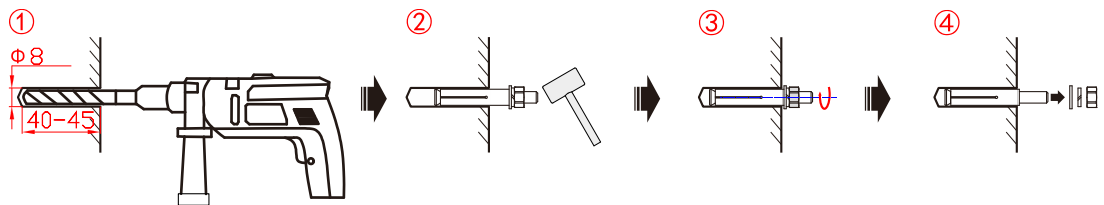

Figure3-29 Insert the expansion plugs (unit: mm)

3. Attach the wall bracket to the wall using seven M5 Self-tapping screws with the tool of screwdriver, as shown in Figure3-30.

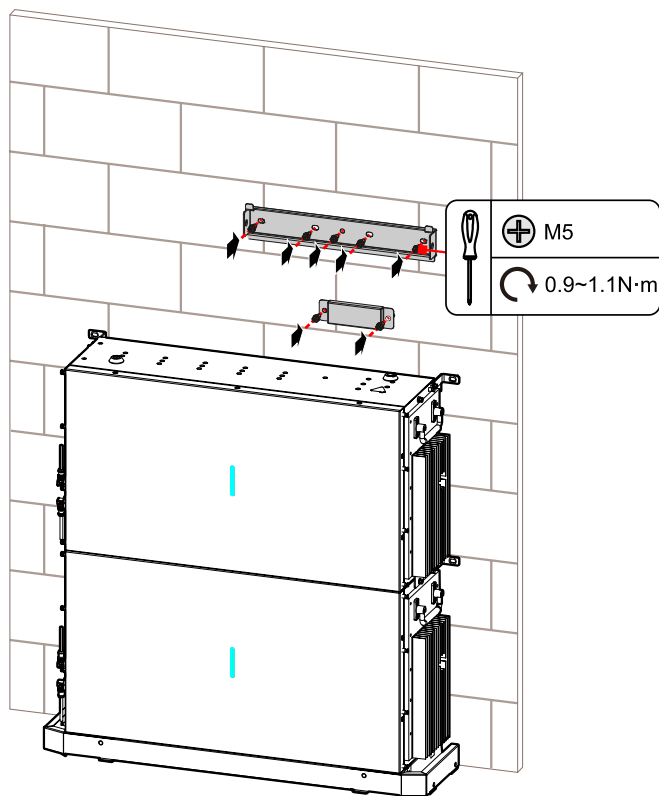

Figure3-30 Install inverter wall bracket

4. Hang the inverter to wall-mounted bracket and tighten the wall bracket and the inverter with screw M6.

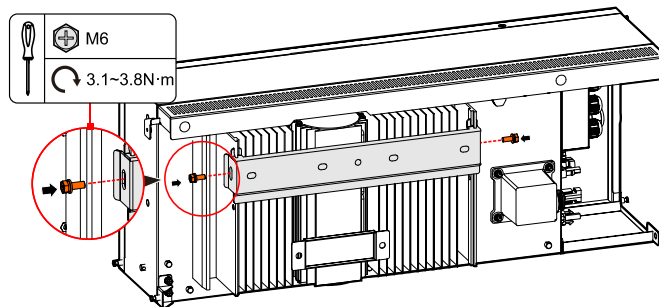

Figure3-31 Tighten the inverter

**NOTE**

Before hanging the inverter on the wall bracket, the battery wiring on the side of the inverter needs to be plugged in first and wiring from the back of the inverter, then tie it.

3.5 Electrical Connection

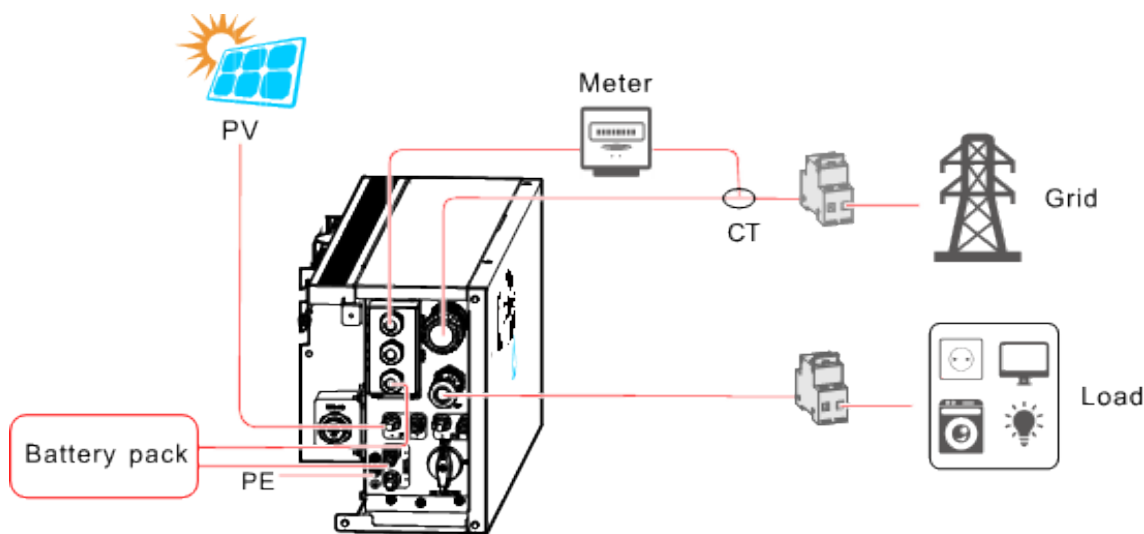

Figure3-32 Electrical connection

3.5.1 Components Requirement

Table3-2 Recommended isolator, over current protection device, and RCD specification

No.	Components	Specification	Scope of supply
①	PV DC switch PEDS150-HM32R-4	23A	Integrated in the inverter
②	Circuit breaker for AC	32A for 3600VA 50A for 5000VA 63A for 6000VA	Purchased by the installer
③	Circuit breaker for backup	20A for 3600VA 25A for 5000VA 32A for 6000VA	Purchased by the installer
④	RCD	Type B 30mA, <0.3S	Purchased by the installer

3.5.2 External Grounding Connection

The external grounding terminal of inverter as shown in ⑦ of Figure2-2.

WARNING

The external grounding wire cannot replace the PE wire of AC output terminal, they must be connected with ground reliably.

- Step 1 Strip the insulation layer of grounding wire for about 7mm, insert the wire into OT terminal and crimp them by crimping tool, the as shown in Figure3-33.

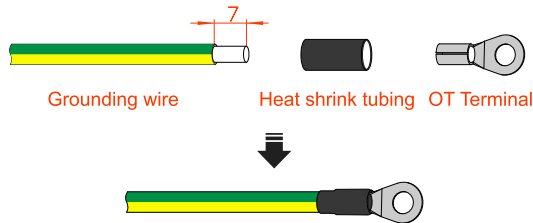

Figure3-33 Stripping diagram of external grounding wire (unit: mm)

- Step 2 Connect the external grounding wire to the inverter.

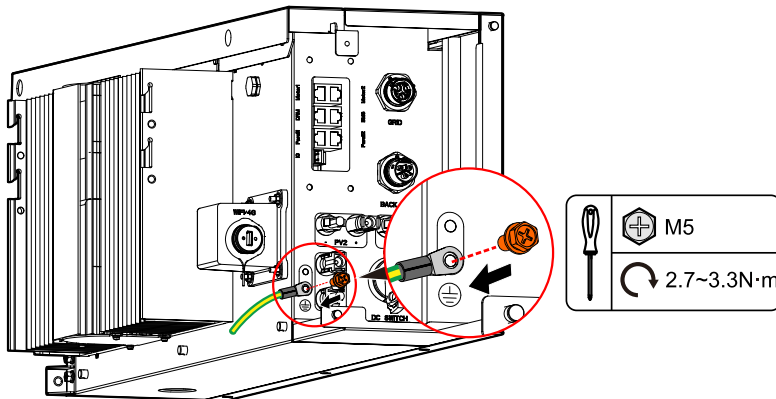

Figure3-34 External grounding connection

CAUTION

- The grounding of the inverter and the lightning rod of the building that inverter installed cannot be the same, the two need to be separated (as shown in Figure3-13), or, lightning stroke will damage the inverter.
- The grounding of the inverter should be directly connected to the grounding system, and the impedance should be less than 20mΩ.
- The inverter can be set to enable grounding detection. If there is a fault, the earth fault will be displayed on the fault alarm interface.

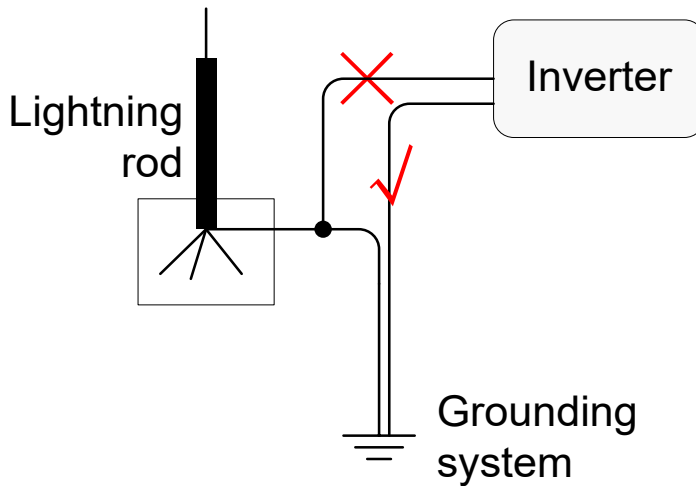

Figure3-35 Grounding diagram of inverter

---End

Step 3 Connect the external grounding wire to the inverter.

CAUTION

- While connecting the inner wires of system, it is necessary to make the handle on the battery pack vertical to the side, and lead the battery +/- and BMS communication wires go through the handle, and then connect them. The inner wiring of system must use the configured battery wires.
- During wiring, ensure that the connection of battery+ and battery - are all right.

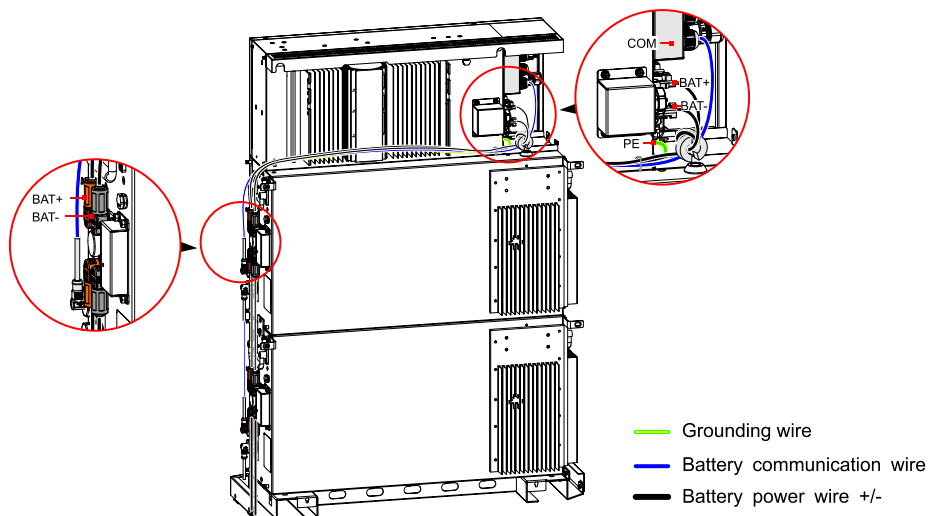

Figure3-36 Battery pack external grounding wire connection

3.5.3 Battery pack connection (electrical connection) (optional as inverter can be used without battery)

CAUTION

- While connecting the inner wires of system, it is necessary to make the handle on the battery pack vertical to the side, and lead the battery +/- and BMS communication wires go through the handle, and then connect them. The inner wiring of system must use the configured battery wires.
- During wiring, ensure that the connection of battery+ and battery - are all right.

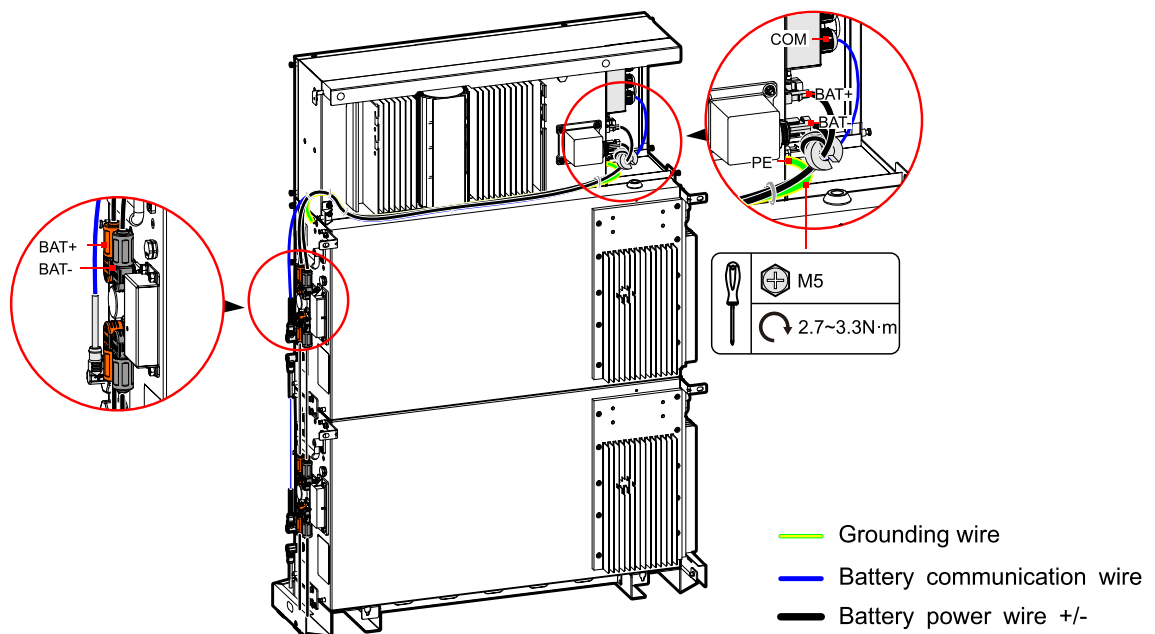

Figure3-37 Battery pack external grounding wire connection

NOTE

If the quantity of battery pack is larger than 4, for easy wiring and lessening the wire length, the other pile of battery packs should be placed at the right of the inverter.

In following figure, we take 1 inverter +2 battery packs as an example to illustrate. The wiring of other configuration is the same

CAUTION

You can install extra batteries up to 8 batteries in a system.

Please install extra batteries one by one, also batteries can be stacked up to four batteries per column. After the battery pack is installed, clean up the excess wires, foam, cardboard boxes and other useless items.

---End

3.5.4 DC Input (PV) Connection

CAUTION

- When installation, it must use the equipped DC terminals to avoid inverter damage.
 - It is recommended to use independent switch for each PV input, and before connecting, the switches must be off. We suggest to use the special DC switch (rated voltage is 600V, rated current is more than 20A).
 - Switch off the DC switch and external DC switches before connecting the PV array.
 - Ensure that the connection between PV array and the inverter at positive pole and negative pole is correctly.
 - The DC input voltage should be less than the max. input voltage of the inverter.
 - It's forbidden to connect the grounding wire with positive pole or negative pole of PV array, or it will lead to inverter damage.
-

Use the equipped PV connector and metal terminal to connect the PV input. The PV connector includes positive connector and negative connector, they match the corresponding positive metal terminal and negative terminal, corresponding procedure as follows.

Step 1 Strip the insulation layer of positive wire and negative wire for about 7mm, as shown in Figure3-38.



Figure3-38 Stripping diagram of DC input (unit: mm)

NOTE

It is recommended to use red wire as the positive wire, use black wire as negative wire to avoid wrong connection. If using the wires of other color, please confirm the corresponding connection relationship.

- Step 2 Unscrew the lock nut of positive and negative connection, lead the positive and negative wires go through corresponding lock nut, and then insert the positive wire and negative wire into the positive metal terminal and negative metal terminal respectively. Crimp the metal terminals firmly by crimping pliers, as shown in Figure3-39.

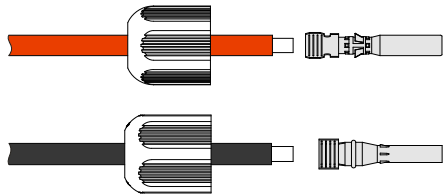

Figure3-39 Crimp the metal terminal

- Step 3 Insert the positive wire and negative wire into corresponding insulation crust respectively. If there has a click sound, it means that the wire have been inserted properly, as shown in Figure3-40.

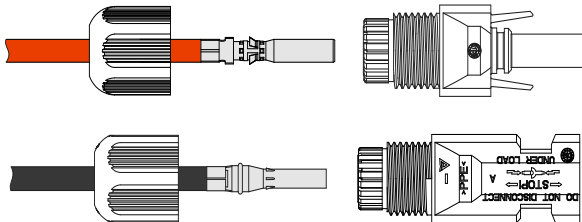

Figure3-40 Fasten the metal terminal

- Step 4 Tighten the sealing nuts of positive connector and negative connector to the corresponding insulation crusts respectively, as shown in Figure3-41.

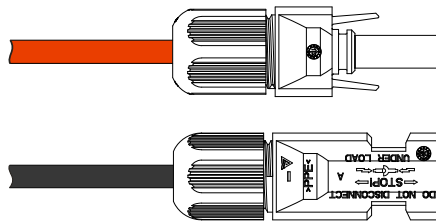

Figure3-41 Tighten the sealing nuts

- Step 5 Measure the voltage and check if the positive and negative is connected properly and if the voltage within the input range of the inverter.
- Step 6 Insert the positive connector and negative connector (black) to the PV+ and PV- terminals (as shown in Figure3-42) and tighten them. If there has a click sound, it means that the connector have been inserted properly.

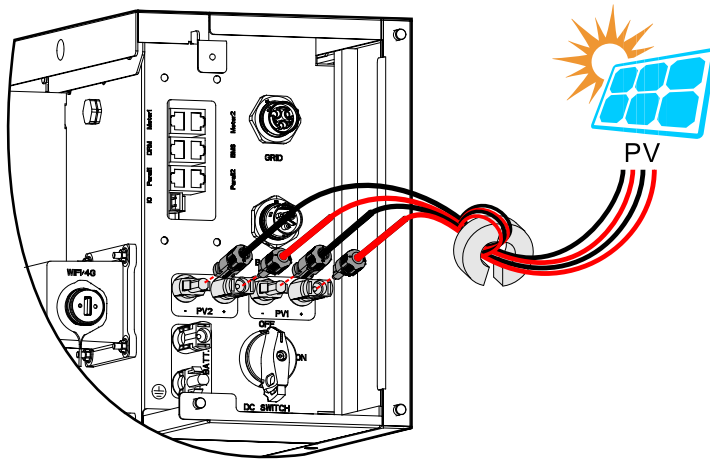

Figure3-42 Connect the PV connector

---End

3.5.5 AC Output Connection

⚠ CAUTION

It's forbidden that several inverters shares an AC switch.

It's forbidden to connect with load between inverter and AC switch.

To ensure the inverter can be disconnected with load safely, we suggest equipping independent dipolar switch for each inverter to protect the inverter.

Table3-3 Recommended AC breaker specification

Model	AC input specification (GRID)	AC output specification (BACKUP)
iHome-INV3.6k-H1H01	32A	20A
iHome-INV5k-H1H01	50A	25A
iHome-INV6k-H1H01	63A	32A



During wiring, please pay attention to distinguish the AC live wire, neutral wire and grounding wire.

GRID wire connection (6mm²-10mm² cable recommended)

Step 1 Ensure that the external grid switch is OFF.

Step 2 Strip wire for about 11mm, the strip instructions and GRID port markings are as shown in Figure3-43.

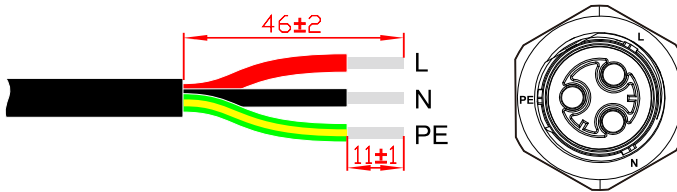

Figure3-43 Wire Stripping (unit: mm)

Step 3 Set the parts on the cable one by one. Wire crimping cord end terminal can be inserted into the housing quickly according to the sign.

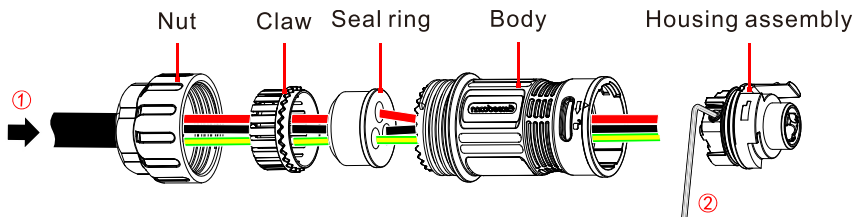

Figure3-44 GRID connector installation 1

Step 4 The housing is inserted into socket.

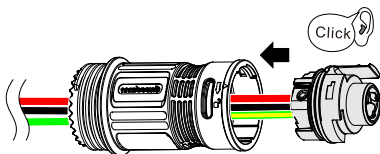

Figure3-45 GRID connector installation 2

Step 5 Inserted the unlock key into socket, and insert seal and Clamp Finger into socket, and then tighten the nut.

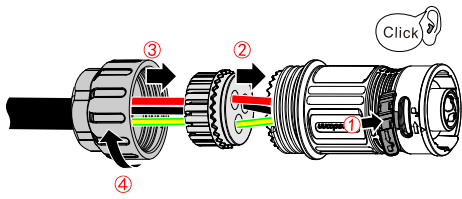

Figure3-46 GRID connector installation 3

Step 6 Connect the GRID wire to the GRID port, if there has a click sound, it means that the connector have been inserted properly.

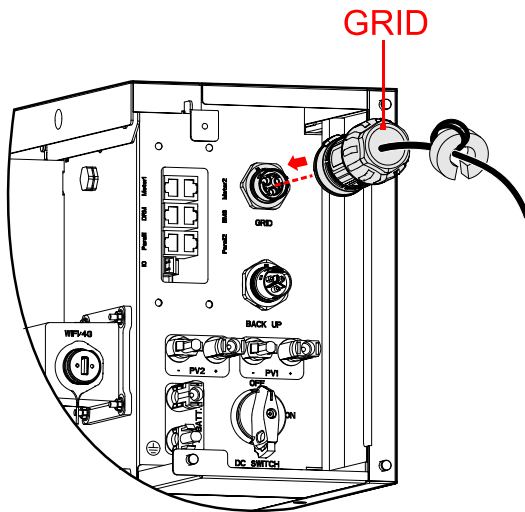

Figure3-47 Insert the GRID terminal

BACKUP wire connection

- Step 1 Ensure that the external backup switch is OFF.
- Step 2 Strip wire for about 10mm, the strip instructions and BACKUP port markings are as shown in Figure3-48.

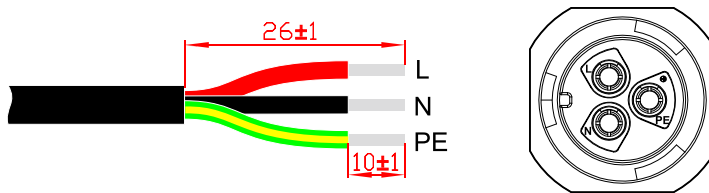

Figure3-48 Wire Stripping (unit: mm)

Step 3 Set the parts on the cable.

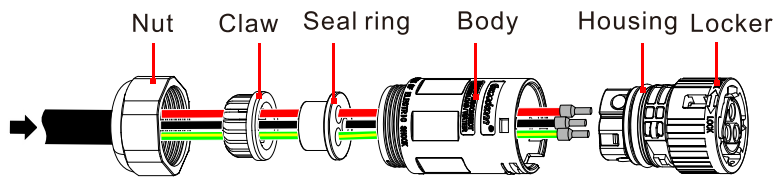

Figure3-49 Insert the BACKUP terminals

Step 4 Crimp wires, screw, push housing into body and locker rotate outward 15°.

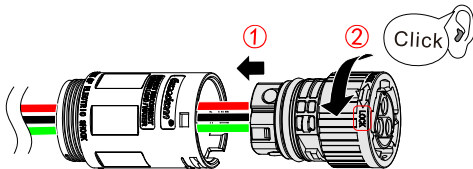

Figure3-50 BACKUP connector installation 1

Step 5 Insert Seal and Clamp Finger into body and tighten the nut. then inserted the unlock key into socket.

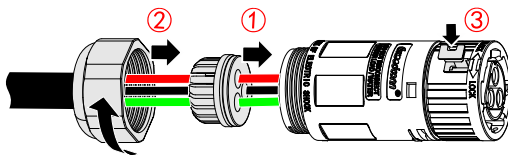

Figure3-51 BACKUP connector installation 2

Step 6 Connect the BACKUP wire to the BACKUP port. As shown in Figure3-52.

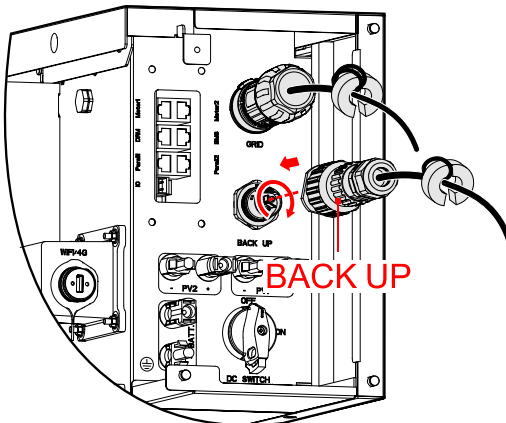

Figure3-52 Insert the BACKUP terminal

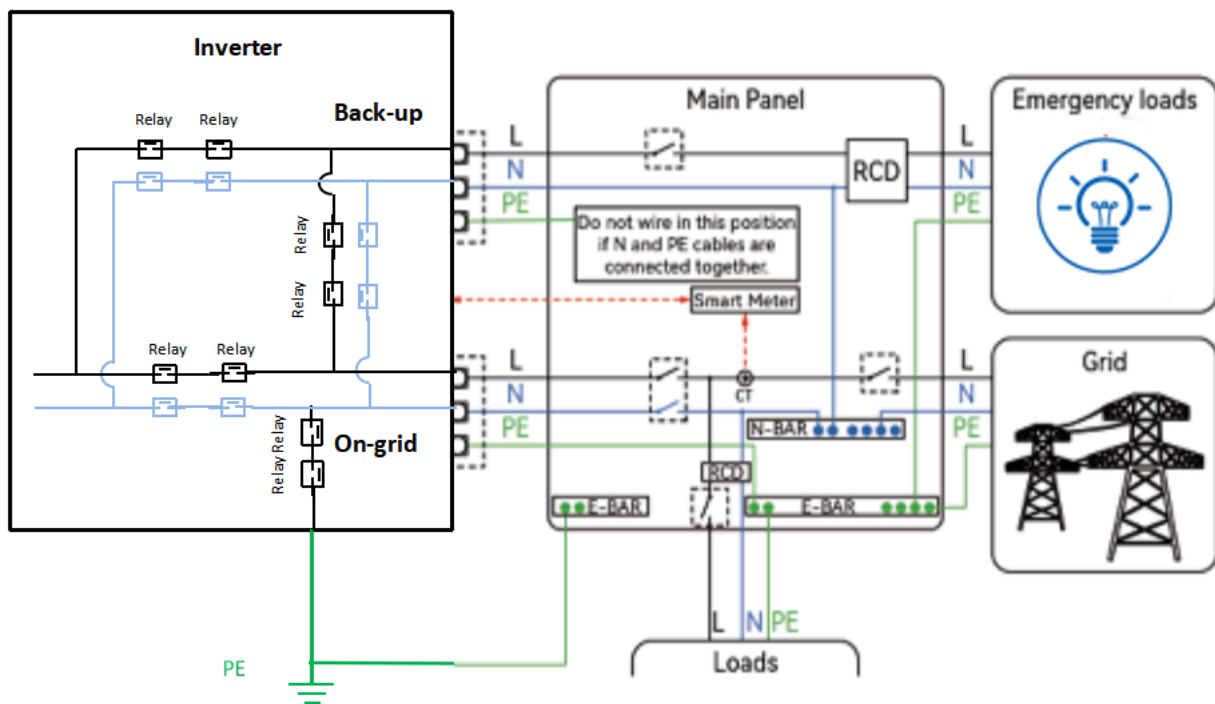

Figure3-53 N wire connection diagram (The internal relay of On-grid is disabled for AU and NZmarket)

NOTE

For Australia and New Zealand, neutral continuity is maintained for the backup loads as part of the installation.

3.5.6 WIFI Connection

CAUTION

Please scan the QR code on the WiFi module in advance for registration or take photos of the QR code on the WiFi module in advance to prevent users from being unable to scan the code after the side cover is installed.

The inverter is equipped with WIFI, install it to the WIFI port (as shown in Figure3-31) to monitor on the internet. The monitor way is as shown in Figure3-31.

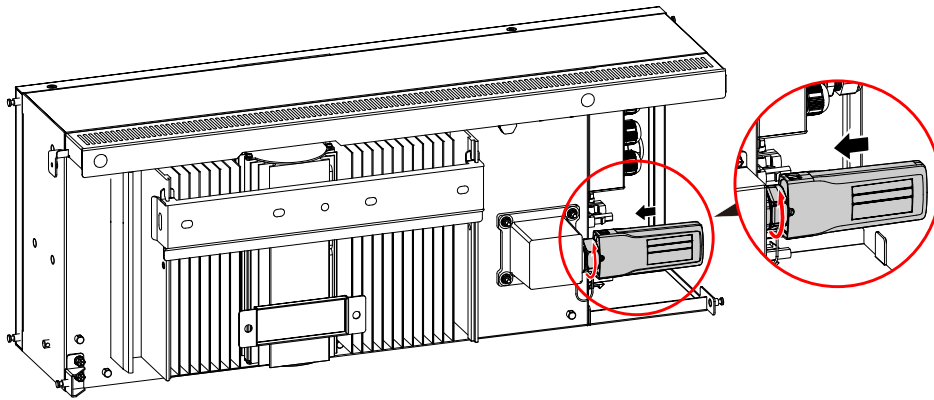

Figure3-54 WIFI communication connection

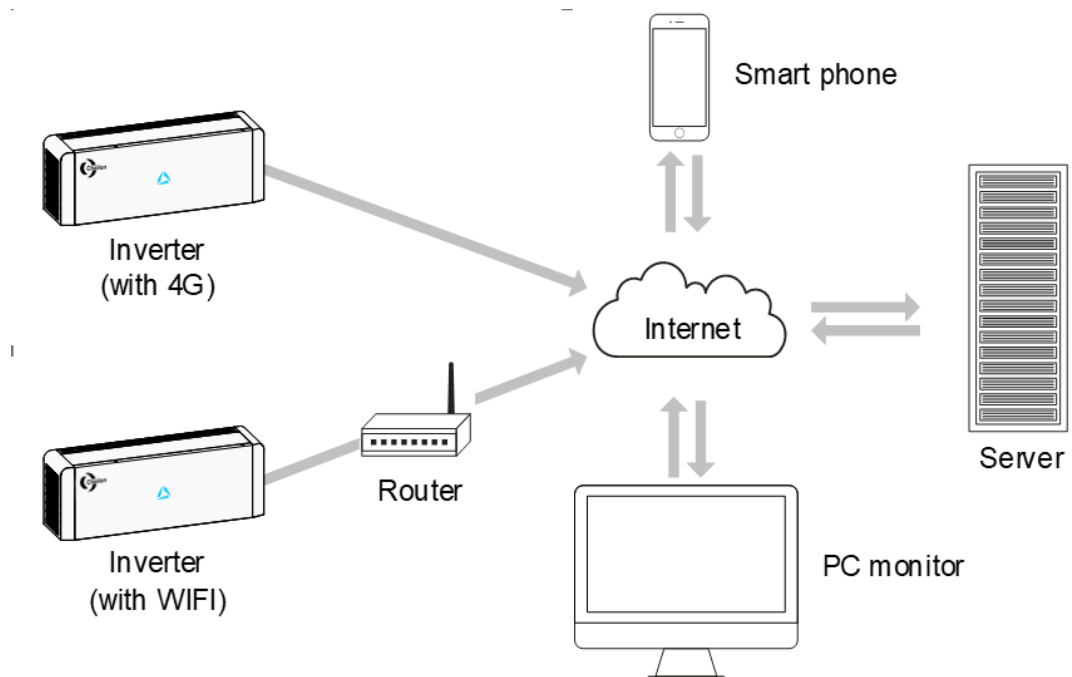

Figure3-55 Communication way

NOTE

For the use of WIFI/4G, please see the built-in user manual in the packaging of WIFI.

3.5.7 Communication Port Connection

Communication ports include DRM port, Meter port and BMS port, they all adopt RJ45 plug to connect. The pin definition of RJ45 plug is as shown in Figure3-56 and Figure3-57.

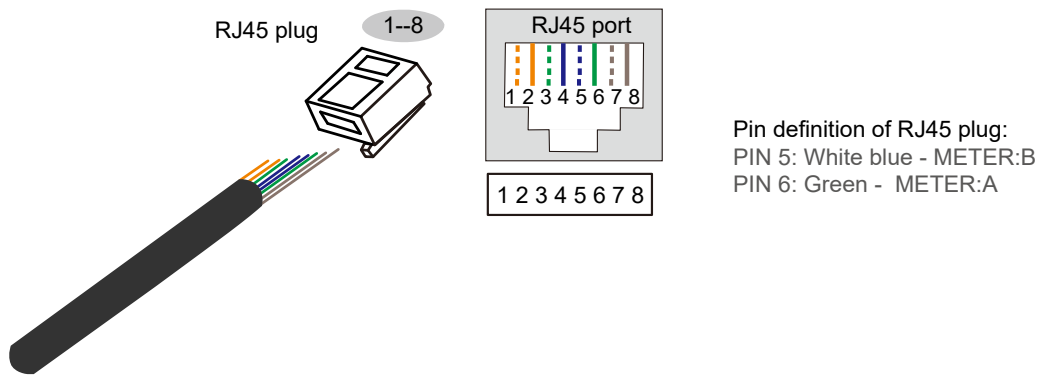

Figure3-56 Meter pin definition

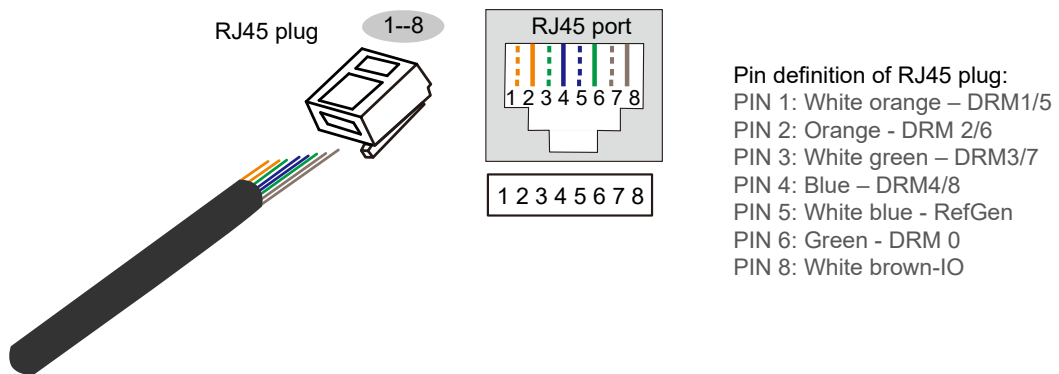

Figure3-57 DRM pin definition

NOTE

1. Strip the communication wire 20mm, and arrange the wire according to the color as shown in the above diagram
2. After inserting the terminal head, you need to push the wire to the top with force. After crimping the terminal, you need to check if the top is in good contact. If the meter still can't communicate after connecting, you need to recheck if the crimping is correct.

DRM port

DRM communication port is used to connect the DRM controlling device.



When using DRM port, the PIN7 and PIN8 of inverter's RJ45 plug cannot connect wires. The PIN7 and PIN8 of external DRM adapter's RJ45 plug must be short connected together.

Meter port

Meter communication port is used to communicate with smart meter to achieve zero-export. The connection between smart meter and inverter and grid is as shown in Figure3-58, Figure3-59, Figure3-60, Figure3-61.

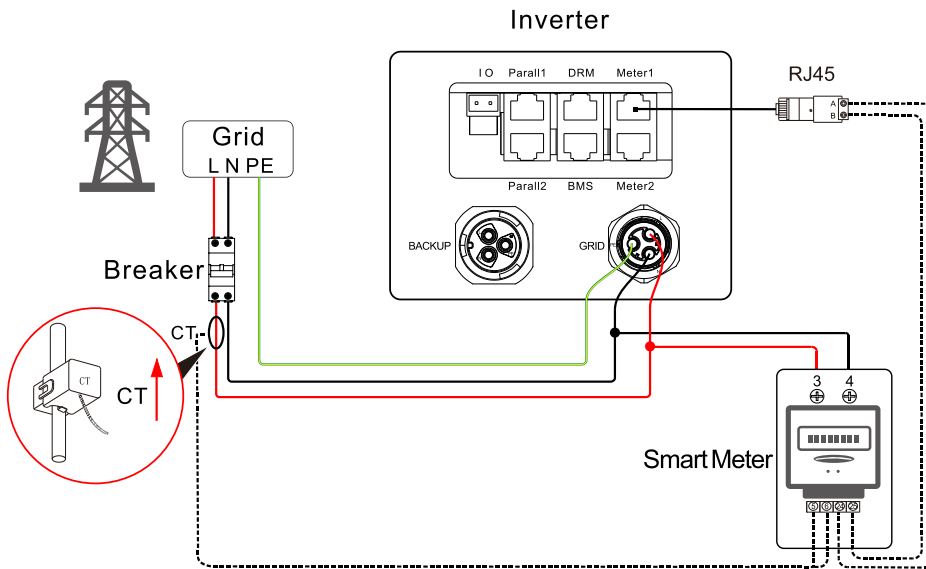

Figure3-58 Connection diagram between communication smart meter and inverter and grid (single phase)

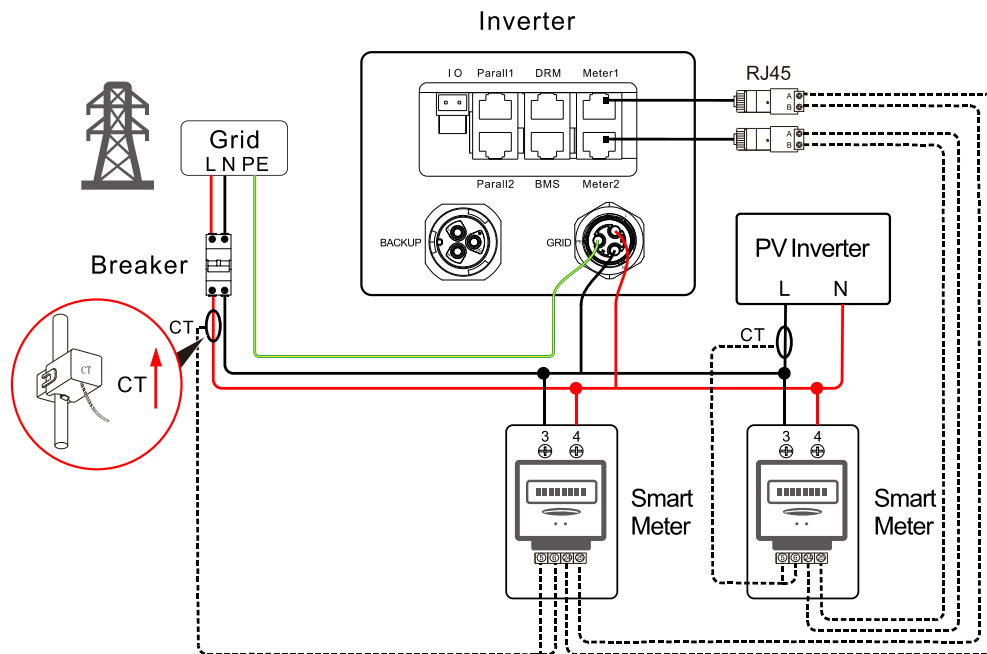

Figure3-59 Connection diagram between communication smart meter and inverter and grid (single phase + single phase)

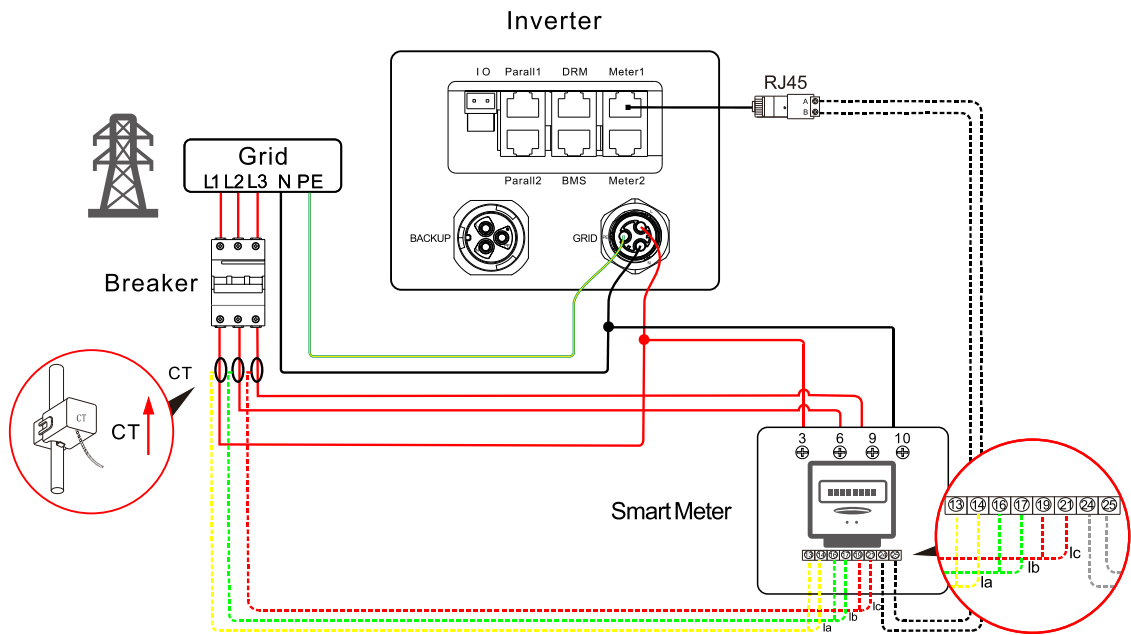

Figure3-60 Connection diagram between communication smart meter and inverter and grid (three-phase)

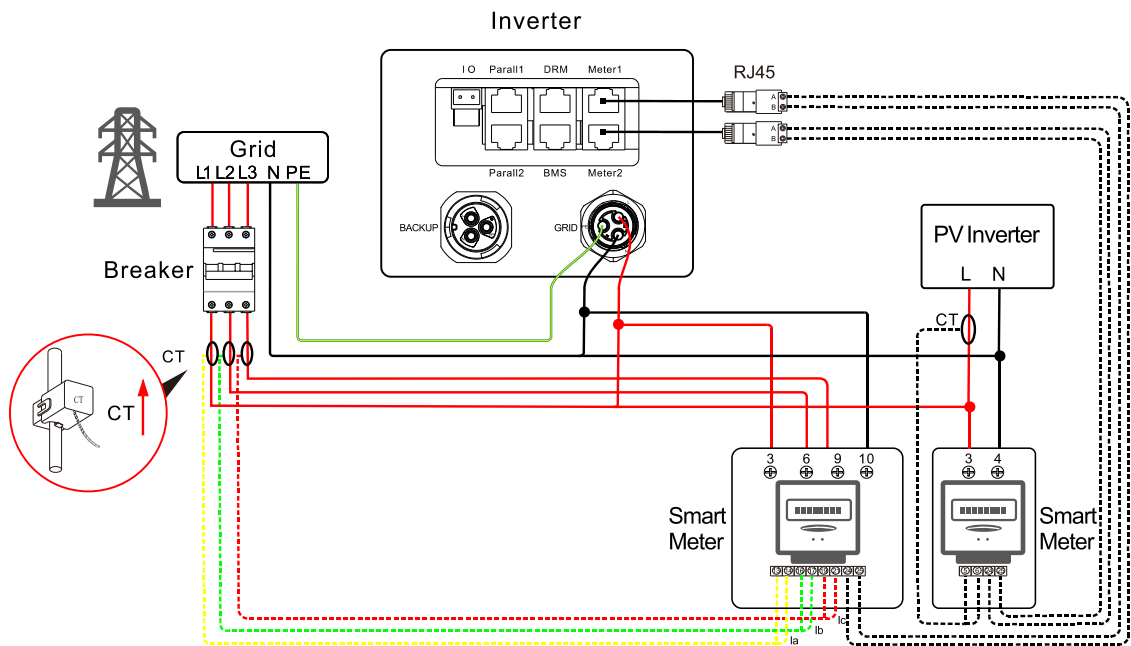

Figure3-61 Connection diagram between communication smart meter and inverter and grid (three-phase + single phase)

NOTE

For the actual wiring of the smart meter, see the diagram on the right side of the meter.
 The manual uses Chint smart meter as the description. If you need to set other parameters or other models, please refer to the corresponding manual of the meter for wiring and setting.



CT direction is: inverter → grid, please connected properly!

Smart meter setting

Step 1 If the smart meter is connected, please do the following setting.



- If the meter used in the grid side of iHome product, address is set to A-001.
- If the meter used in the PV inverter grid side, address is set to A-002.
- When there is a PV inverter in the user's home, it is recommended to install the smart meter in the grid output side of the PV inverter to ensure the accuracy of grid electricity statistics, and the address is set to A-002. As shown in the Figure3-62 and Figure3-63.

When using the zero-export function, the following setting are required:

1. Set the "Zero-export function" to enable in " Basic setting".

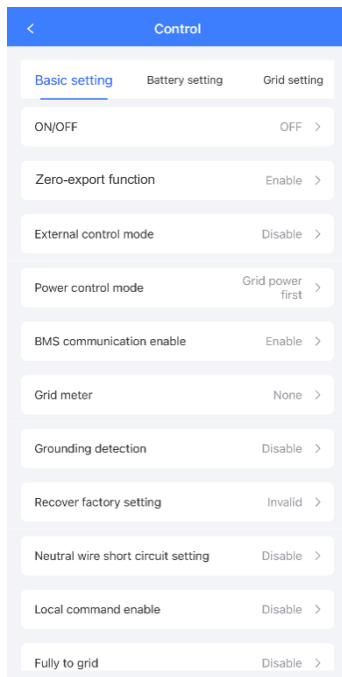

Figure3-62 Set "Zero-export function"

- Set the "Anti-backflow control power" in "Basic setting" according to the actual use (the setting value of anti-backflow control power is percentage, it is corrected by rated power. For example, when the rated power of the inverter is 5kW, if the zero-export power set to 30%, the set anti-backflow control power is 1.5kW).

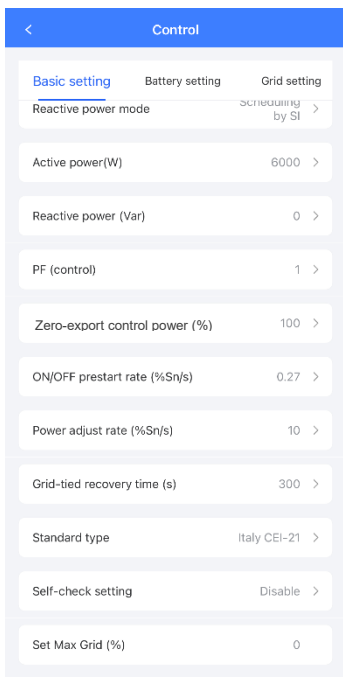

Figure3-63 Set "Anti-backflow control power"

The pin illustration of smart meter is as shown in Step 1 and Table3-4.

Table3-4 Pin illustration of smart meter (single phase)

Pin	Illustration
3	Connect to phase-L of GRID port in the inverter and phase-L of grid output.
4	Connect to phase-N of GRID port in the inverter and phase-N of grid output.
5	Connect to I+ port of current transformer in the meter.
6	Connect to I- port of current transformer in the meter.
24	RS485: A. Connect to RJ45's pin6 of communication port in the inverter.
25	RS485: B. Connect to RJ45's pin5 of communication port in the inverter.

Table3-5 Pin illustration of smart meter (three- phase)

Pin	Illustration
3	Connect to phase-L of GRID port in the inverter and L1 of grid output.
6	Connect to L2 of grid output.
9	Connect to L3 of grid output.
10	Connect to phase-N of GRID port in the inverter and N of grid output.
13	Connect to I+ port of current transformer of grid output L1.
14	Connect to I- port of current transformer of grid output L1.
16	Connect to I+ port of current transformer of grid output L2.
17	Connect to I- port of current transformer of grid output L2.
19	Connect to I+ port of current transformer of grid output L3.
21	Connect to I- port of current transformer of grid output L3.
24	RS485: A. Connect to RJ45's pin6 of communication port in the inverter.
25	RS485: B. Connect to RJ45's pin5 of communication port in the inverter.

The setting of the smart meter address is as shown in Figure3-64 and Figure3-65.

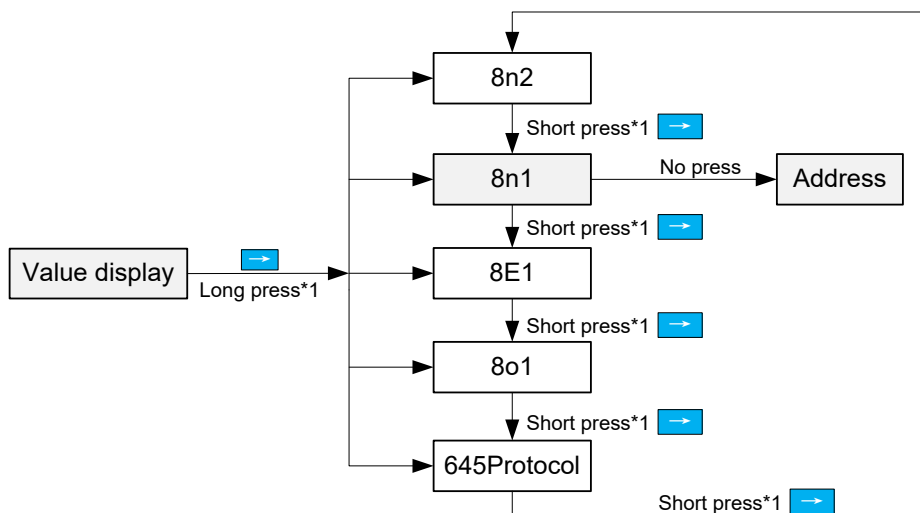

Figure3-64 The setting of the smart meter address (single phase)

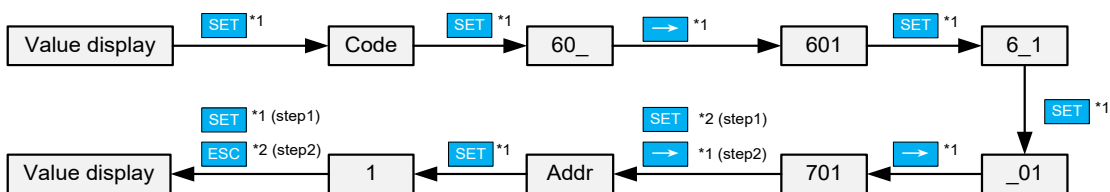

Figure3-65 The setting of the smart meter address (three- phase)

The connection procedure of communication port is as follows.

- Step 1 Unscrewing the lock nut, insert the RJ45 port to the communication port after through the magnetic ring and COM wiring cover (as shown in Figure3-66),

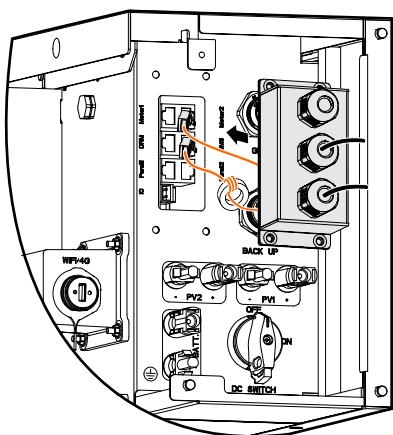

Figure3-66 Insert the communication port

- Step 2 Screw the COM wiring cover to the inverter and tighten the two nylon cable glands with tool of screwdriver.

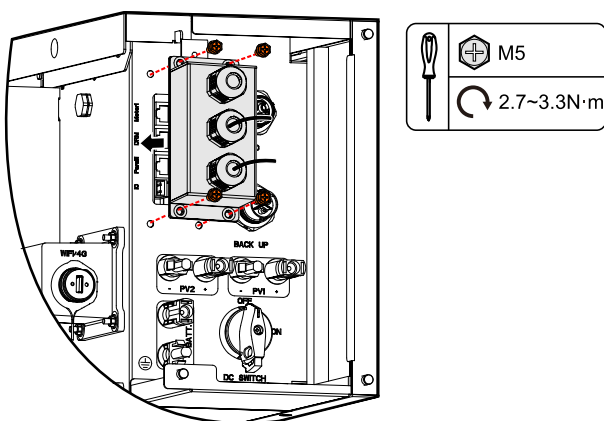

Figure3-67 Screw the COM wiring cover

----End

3.6 Side Cover Plate Installation

After wiring connection, install side cover plate to the inverter as follows.

CAUTION

While fixing the cover plates, it is necessary to lead the corresponding wires go through the groove of cover plate and fasten them to avoid extruding for the wires and even cause damage for the wires and affect the normal use.

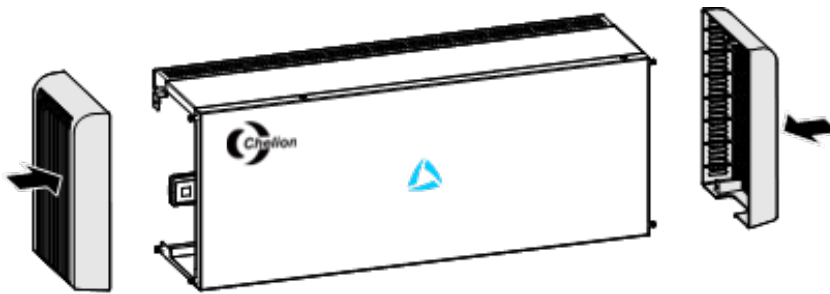

Figure3-68 Tighten the wiring cover plate

NOTE

Ensure that the installed wall is flat and horizontal. If not, please use gasket to make the wall horizontal.

---End

3.7 Check the Installation

After installation, check the following items:

- Check if the connection of DC input, AC output and communication wire are right.
- Check if the iHome product is installed firmly.
- Check if all the wiring are tightened.

4 APP Operation

This chapter is mainly introduces the operation of APP.

Login the following website to download the APP and do WIFI configuration.

www.chelion.au

5 Startup and Shutdown

This chapter introduces how to start and shut down the device.

5.1 Startup

Step 1 Check whether the PV, backup and grid wiring correct.

Step 2 Turn on the external load switch.

Step 3 Turn on external grid switch.



After turning on the grid switch, iHome series energy storage system will be started automatically.

Step 4 Turn on the DC switch on the inverter and external PV switch.

Step 5 Before start the inverter, you should set the inverter function via APP. The mode can be set to time of use mode, backup mode, self consumption mode, energy scheduling mode, external control mode and peakload shifting mode. For detail, please see 1.

Step 6 Perform the following operation according to the actual condition.

- If the LED indicator on the front panel of inverter light on, connect the WIFI and confirm the system parameters and then perform the startup operation on the basis of actual condition.
 - If PV>120V, select ON in **Basic setting** of APP to start the system.

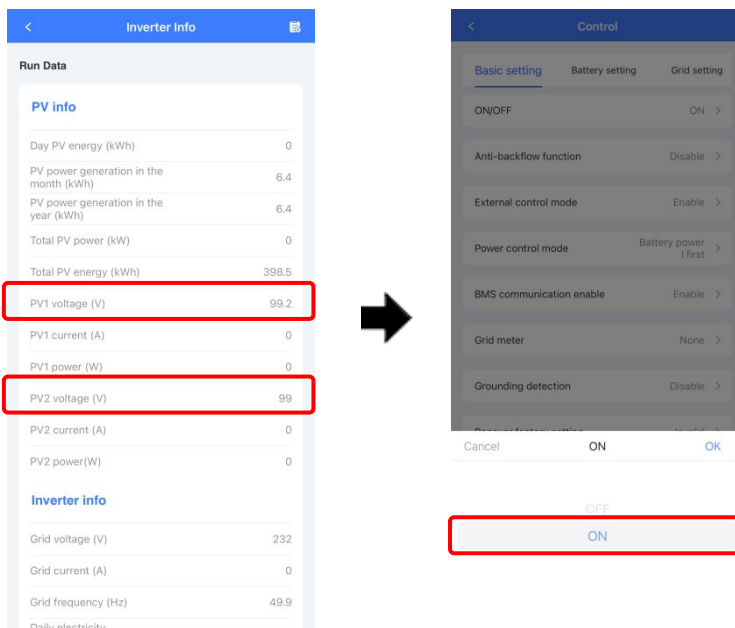

Figure5-1 Start with PV

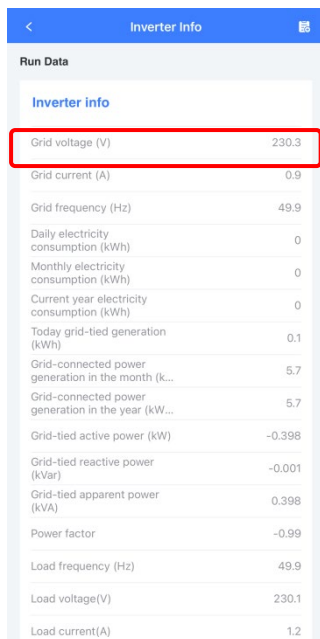

Figure5-2 Check the grid voltage

NOTE

For the use of WIFI/4G, please see the built-in user manual in the packaging of WIFI.

Step 7 When the DC and AC supply power normally, the inverter will prepare to start, 60s later, the system is operating normally, or check the insulation impedance.

Step 8 About 60s, the inverter will generate power normally. LED is always on.

Step 9 Working status can be queried on the APP.

----End

5.2 CEI Self-Check

NOTE

The iHome product has the CEI self-check function, which is required only in Italy. Other countries do not need to operate.

It is recommended to perform the self-check operation when the grid is normal. Self-check function of CEI is integrated in Master APP for Italy safety country requirement. The function can only be operated in the local APP mode. The specific operation steps are as follows.

Step 1 Operate in the APP login interface as below.

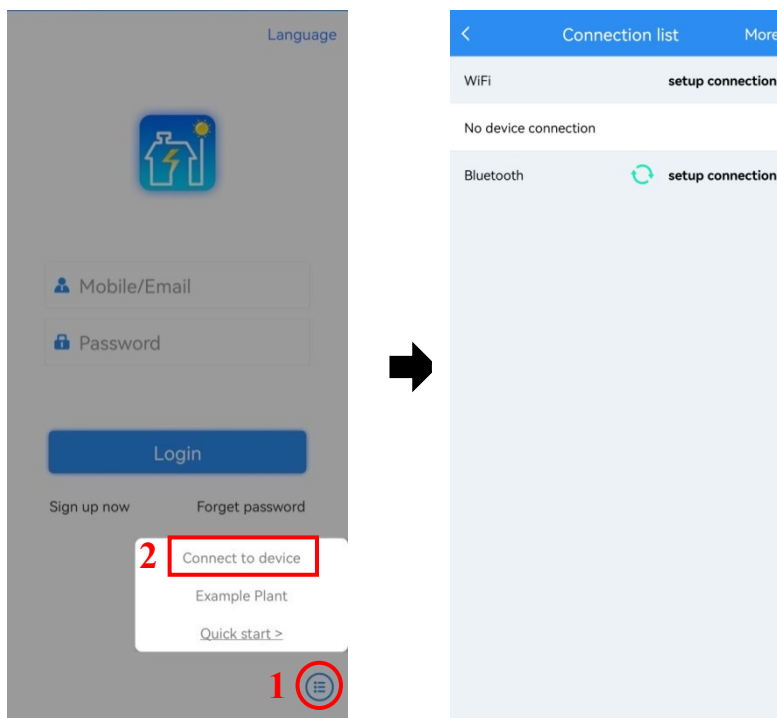

Figure5-3 Connect to device

Step 2 The mobile phone needs to be connected to the WIFI of the device (the picture below are example, the WIFI password is 12345678), if it doesn't exit, refresh.

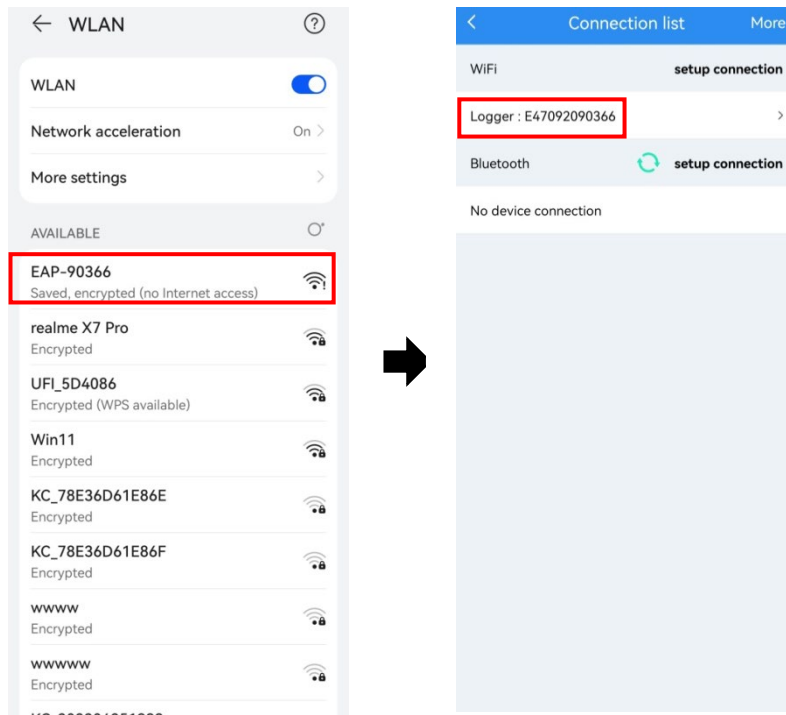

Figure5-4 Connect to WLAN

Step 3 Click "View device" in the logger interface, and then click "Customer".

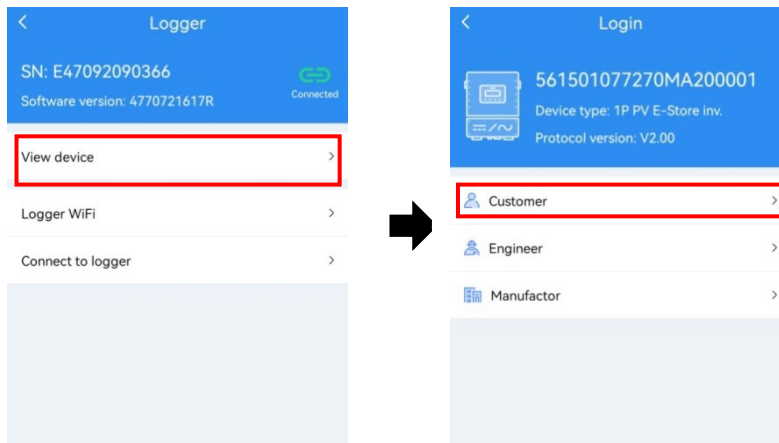

Figure5-5 Enter the customer interface

Step 4 Click "Start" in the monitor interface and click "Done" in the popup. Then the device starts self check.

5 Startup and Shutdown

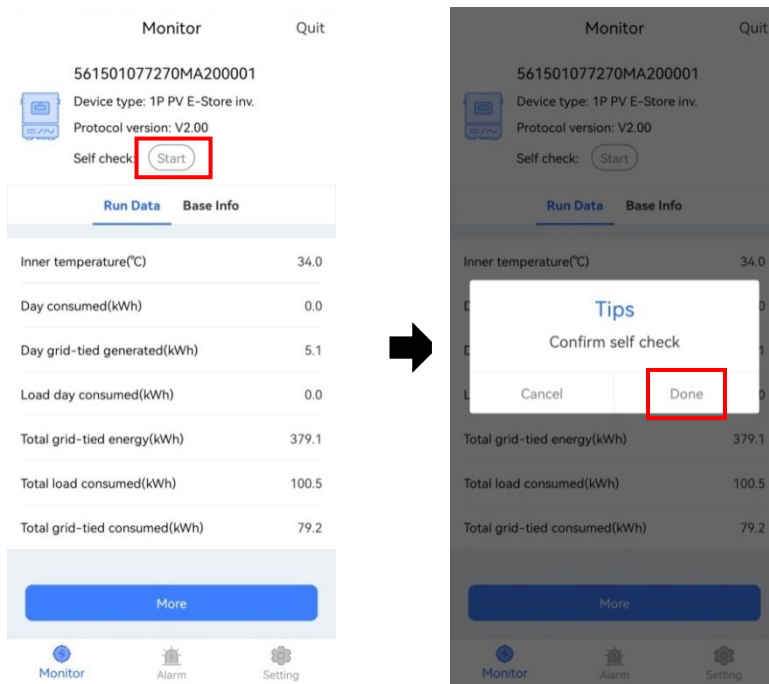

Figure5-6 Start the self check function

Step 5 Click "More" in the "Monitor" interface to view the self check info.

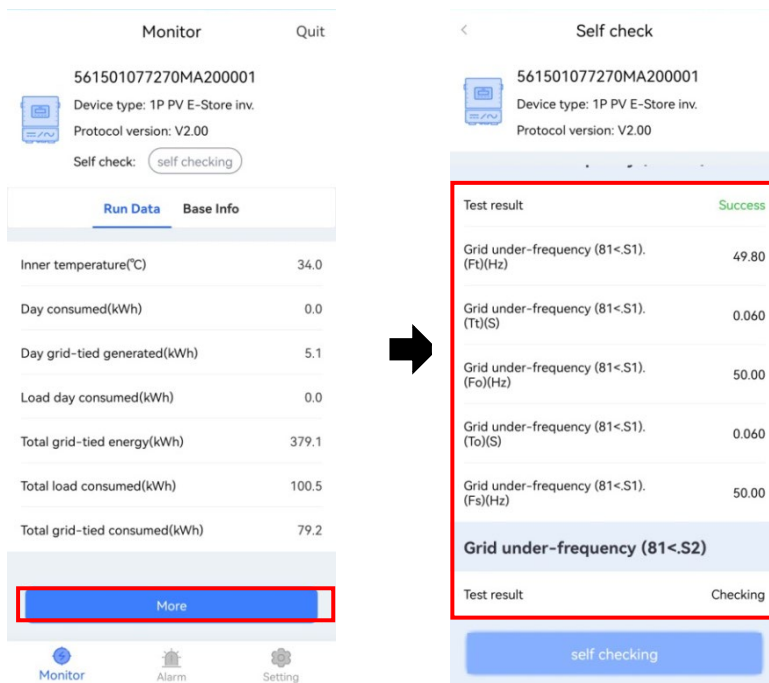

Figure5-7 View test results

----End

5.3 Shutdown

Step 1 Powering off the inverter on the APP.

Step 2 Switch off the PV breaker and the grid breaker, wait for the inverter indicator light to be off.

5.4 Generation control function

Set Generation/Export limit control – Hard limit control.

In the "**Other setting**" item, you can enable Generation/Export limit control– Hard limit control.

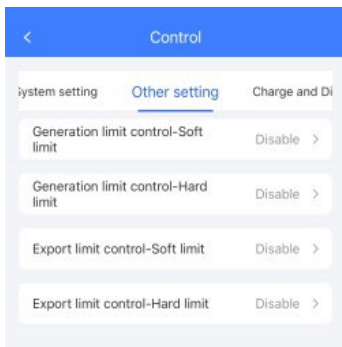

Figure5-8 Hard limit control

 **NOTE**

These parameters can be set between 0 and 100%

6 Maintenance and Troubleshooting

This chapter mainly introduces the maintenance and troubleshooting for device.

6.1 Maintenance

The energy storage system iHome series needn't to be maintained regularly, but the sundries or dust may influence the heat dissipation performance, so, use soft brush to clean the inverter. If the LED indicator is too dirty to view, use a wet cloth to clean them.

WARNING

During running, do not touch the inverter. The temperature of some parts on the inverter is too high, and may cause scald injury. After shut down the inverter and wait until it cooling down, then do the maintenance and clean.

CAUTION

Do not clean the inverter with any solvent, abrasive material or corrosive material.

Disconnect the inverter from all power sources before cleaning. Clean the housing, cover and display with a soft cloth.

To ensure that the inverter can operate properly in the long term, you are advised to perform routine maintenance on it as described in this chapter.

Table6-1 Maintenance checklist

Check Item	Acceptance Criteria	Maintenance Interval
Product cleanliness	The heat sink of the inverter are free from obstacles or dust.	Semiannually or once per year
Product visible damage	The inverter is not damaged or deformed.	Semiannually

Check Item	Acceptance Criteria	Maintenance Interval
Product running status	<ol style="list-style-type: none"> 1. The inverter operate with no abnormal sound. 2. All parameters of the inverter are correctly set. Perform this check when the inverter is running. 	Semiannually
Electrical connections	<ol style="list-style-type: none"> 1. Cables are securely connected. 2. Cables are intact, and in particular, the cable jackets touching the metallic surface are not scratched. 3. Unused PV input terminals, unused communication ports of the inverter, power and COM terminals of the battery pack are locked by watertight caps if the product is mounted outdoor. 	The first maintenance is needed 6 months after the initial commissioning. And then make it semiannually or once per year.

6.2 Troubleshooting

The inverter is designed on the basis of the grid-tied operation standards and meets the requirements of safety and EMC. Before provided to client, the inverter has been experienced for several rigorous tests to ensure reliable and optimizing operation. The troubleshooting is as shown in Table6-2.

Table6-2 Troubleshooting

Check item	Fault description	Solution
DC bus over-voltage	Bus voltage is too high.	<ol style="list-style-type: none"> 1. Check whether the input voltage of PV1 and PV2 exceed 580V. 2. If not, restart the inverter to see if the fault still exists. If it still exists, contact service.
Insulation resistance abnormal	DC side-ground impedance is too low.	<ol style="list-style-type: none"> 1. If the power on time fails in the morning, it may be caused by wet weather. 2. Use a multimeter to test the impedance of the ground to the housing. If the impedance is

Check item	Fault description	Solution
		<p>not close to 0, confirm that there is a connection problem between the ground wire and the housing.</p> <p>3. Test the impedance of ground to PV+/PV-/BAT+/BAT- with a multimeter. If the impedance is less than 25KΩ, check whether the connection of each port is correct.</p> <p>4. Confirm to install the device according to the user manual.</p> <p>5. Restart the inverter to see if the fault still exists. If it still exists, contact customer service.</p>
Residual current protection	Residual current exceed allow range	Restart the inverter to see if the fault still exists. If it still exists, contact customer service.
Residual current hall abnormal	residual current detection sensor abnormal	Restart the inverter to see if the fault still exists. If it still exists, contact customer service.
Relay abnormal	Grid-tied relay/bypass relay/grid-off relay abnormal	<p>1. Confirm to install the inverter according to the manual.</p> <p>2. Restart the inverter to see if the fault still exists. If it still exists, contact service.</p>
Neutral-to-ground abnormal	When off-grid, neutral-to-ground wire is disconnected.	<p>1. Check whether neutral-to-ground wire of off-grid side is short-circuited with a multimeter.</p> <p>2. Restart the inverter to see if the fault still exists. If it still exists, contact customer service.</p>
Inner over-temperature	Ambient temperature is too high.	<p>1. Try to lower the ambient temperature.</p> <p>2. Make sure that the inverter is installed according to the manual and there is no shelter</p>

Check item	Fault description	Solution
		<p>around the inverter.</p> <p>3. After the inverter is powered off and waiting for 30 minutes, then restart it. If the fault still exists, contact service.</p>
Inner communication abnormal	Inner communication abnormal	<p>1. After waiting for a while, check whether fault will recover.</p> <p>2. Restart the inverter to see if the fault still exists. If it still exists, contact customer service.</p>
RTC abnormal	Clock chip abnormal	<p>1. After powering off and restarting, check whether it is abnormal.</p> <p>2. Restart the inverter to see if the fault still exists. If it still exists, contact customer service.</p>
Store abnormal	Inner storage abnormal	<p>1. After waiting for a while, check whether fault will recover.</p> <p>2. Restart the inverter to see if the fault still exists. If it still exists, contact customer service.</p>
PV1 polarity reverse connected	PV1 input reversed	Check whether PV1 wiring is reversed.
PV1 over-voltage	PV1 voltage exceed allow value	Check the PV1 voltage. If it exceeds 585Vd.c., reduce the number of PV modules.
PV1 over-current	PV1 current exceed allow value	<p>1. Try to lower PV power.</p> <p>2. Restart the inverter to see if the fault still exists. If it still exists, contact customer service.</p>
PV2 reverse connected	PV2 input reversed	Check whether PV2 wiring is reversed.
PV2 over-voltage	PV2 voltage exceed	Check the PV2 voltage to see if it exceeds

Check item	Fault description	Solution
	allow value	585V, if exceed, reduce the PV array quantity.
PV2 over-current	PV2 current exceed allow value	<ol style="list-style-type: none"> 1. Try to lower PV power. 2. Restart the inverter to see if the fault still exists. If it still exists, contact customer service.
PV over-temperature	PV side temperature is too high.	<ol style="list-style-type: none"> 1. Try to lower the ambient temperature. 2. Make sure that the inverter is installed according to the manual and there is no shelter around the inverter. 3. After the inverter is powered off and waiting for 30 minutes, then restart it. If the fault still exists, contact service.
BMS communication fault	Abnormal communication with BMS.	Check whether communication wire between BMS and inverter is loosed.
Inverter side over-temperature	Inverter heat sink ambient temperature is too high.	<ol style="list-style-type: none"> 1. Try to lower the ambient temperature. 2. Make sure that the inverter is installed according to the manual and there is no shelter around the inverter. 3. After the inverter is powered off and waiting for 30 minutes, then restart it. If the fault still exists, contact service.
Inverter voltage abnormal	Output voltage abnormal	Check whether voltage and load of grid is abnormal.
Short-circuit protection	When off-grid, the output side is short-circuited	<ol style="list-style-type: none"> 1. Use a multimeter to test the impedance of the off grid output. If it is small, check whether the wiring is correct 2. Restart the inverter to see if the fault still exists. If it still exists, contact service.

Check item	Fault description	Solution
Inverter voltage DC component abnormal	When off-grid, voltage DC component abnormal.	Restart the inverter to see if the fault still exists. If it still exists, contact service.
Inverter current over-current	Inverter current detected on software exceeds the allowable value.	<ol style="list-style-type: none"> 1. Check whether the off grid output terminal is overloaded, short circuited or has impact load. 2. Restart the inverter to see if the fault still exists. If it still exists, contact service.
Inverter current DC component abnormal	When grid-tied, current DC component abnormal.	Restart the inverter to see if the fault still exists. If it still exists, contact service.
Overload	Load is too large.	<ol style="list-style-type: none"> 1. Check whether the load exceeds the rated power. 2. Restart the inverter to see if the fault still exists. If it still exists, contact service.
Grid over-voltage	Voltage exceeds the allowable range.	<ol style="list-style-type: none"> 1. Check whether grid abnormal. 2. Check whether grid wiring abnormal. 3. Restart the inverter to see if the fault still exists. If it still exists, contact service.
Grid under-voltage	Voltage exceeds the allowable range.	<ol style="list-style-type: none"> 1. Check whether grid abnormal 2. Check whether grid wiring abnormal. 3. Restart the inverter to see if the fault still exists. If it still exists, contact service.
Grid over-frequency	Grid frequency exceeds the allowable range.	<ol style="list-style-type: none"> 1. Check whether grid abnormal. 2. Check whether grid wiring abnormal. 3. Restart the inverter to see if the fault still exists. If it still exists, contact service.
Grid under-frequency	Grid frequency exceeds allow range.	<ol style="list-style-type: none"> 1. Check whether grid abnormal 2. Check whether grid wiring abnormal.

Check item	Fault description	Solution
		3. Restart the inverter to see if the fault still exists. If it still exists, contact service.
Grid-tied phase lock abnormal	Phase lock abnormal	<ol style="list-style-type: none"> 1. Check whether grid abnormal. 2. Check whether grid wiring abnormal. 3. Restart the inverter to see if the fault still exists. If it still exists, contact service.
Overload alarm	When off-grid, the load exceeds rated load.	Check whether the load exceeds 0.95 of the rated power.
Inner sensor abnormal	Inner temperature sensor sampling abnormal.	<ol style="list-style-type: none"> 1. Check whether the ambient temperature is low, if it is low, automatic recovery after operating for a while. 2. Restart the inverter to see if the fault still exists. If it still exists, contact service.
DRM alarm	Powered off after DRM enabled.	Normal, no processing.
DC power alarm	Load power exceeds DC power.	1. Restart the inverter to see if the fault still exists. If it still exists, contact service.
Fan fault alarm	Fan abnormal.	<ol style="list-style-type: none"> 1. Check whether the fan is blocked. 2. Restart the inverter to see if the fault still exists. If it still exists, contact service.
Heat sink over-temperature alarm	Temperature is too high to reach the rate drop point.	<ol style="list-style-type: none"> 1. Check whether the environment temperature is too high, try to lower the ambient temperature. 2. Make sure that the inverter is installed according to the manual and there is no shelter around the inverter. 3. After the inverter is powered off and waiting for 30 minutes, then restart it. If the fault still exists, contact service.

Check item	Fault description	Solution
Smart meter abnormal	Communication failure with the meter.	<ol style="list-style-type: none"> 1. Check if the communication wire disconnected. 2. Check meter address and baud rate. 3. Test after exchanging two communication wires.
Heat sink sensor abnormal	Heat sink sampling is less than -39° .	Check the temperature after the product is operating for a while, if the temperature is abnormal, please contact manufacturers.
App communication abnormal	Communication failure with the App.	<ol style="list-style-type: none"> 1. Confirm if the communication baud rate is 9600 and if communication station is 1. 2. Confirm if WIFI module is light on.
Communication with upper computer abnormal	Can't communication with upper computer.	<ol style="list-style-type: none"> 1. Confirm if baud rate and address is correct. 2. Confirm if the wire from the device to PC is normal.
Earth fault	The App alarmed "Neutral-to-ground abnormal" or the panel red light flashing	<ol style="list-style-type: none"> 1. Confirm the neutral line fixed well. 2. Reset the inverter

 **CAUTION**

If the inverter has any alarm information mentioned in Table6-2. please shut down the inverter (refer to 5. 2 Shutdown), 5 minutes later, restart the inverter (refer to 5. 1 Startup). If the alarm status is not removed, please contact our local dealer or service centre. Before contacting us, please prepare the following information.

1. Inverter S/N.
2. Distributor/ dealer of the inverter (if has).
3. The date of grid-tied power generation.
4. Problem description.

5. Your detail contact information.
-

7 Package, Transportation and Storage

This chapter introduces the package, transportation and storage of device.

7.1 Package

The device is packaged by carton. When packaging, pay attention to the placing direction requirements. On the side of the carton, there has warning icons, including keep dry, handle with care, up, stacking layer limit, etc. On the other side of the carton, it prints the device model, etc. On the front side of the carton, there is the logo of Chelion company and device name.

7.2 Transportation

During transporting, pay attention to the warnings on the carton. DO NOT make the device impact severely. To avoid damaging the device, place the device strictly according to the placement direction. DO NOT carry the device with the objects that is inflammable, explosive, or corrosive. DO NOT put the device in the open-air while midway transshipment. Leaching or mechanical damage by rain, snow or liquid objects is prohibited.

7.3 Storage

During storage, place the device strictly according to the direction that showed on the carton. Keep at least 20cm from the bottom of the carton to floor and keep at least 50cm from the carton to wall, heat source, cold source, windows or air inlet. The poisonous gas, inflammable or explosive or corrosive chemical objects are prohibited. Besides, strong mechanical shaking, impact or strong magnetic field is also prohibited. The storage temperature of inverter is -40°C - 70°C .

A Technical Specifications

Item \ Model	iHome-INV3.6k-H1H01	iHome-INV5k-H1H01	iHome-INV6k-H1H01
PV input			
Max. input power (W)	9000		
Max. input voltage (V d.c.)	580		
MPPT voltage range (V d.c.)	100~550		
Max. PV input current (A d.c.)	2*15		
MPPT voltage range with full-load (V d.c.)	300~450		
Startup voltage (V d.c.)	100		
MPPT number	2		
Per MPPT string number	1/1		
Max. PV short-circuit current (A d.c.)	18.75		
Max. inverter feedback current to array (A a.c.)	0		
Grid input			
Rated input power (VA)	7200	10000	12000
Max. apparent power (VA)	7200	10000	12000

Item \ Model	iHome-INV3.6k-H1H01	iHome-INV5k-H1H01	iHome-INV6k-H1H01
Rated voltage (V a.c.)	230		
Rated input current (A a.c.)	31.2	43.4	52.4
Max. continuous input current (A a.c.)	31.2	43.4	52.4
Rated grid frequency (Hz)	50/60		
Grid output			
Rated output power (VA)	3600	5000	6000
Max. apparent power (VA)	3600	5000	6000
Rated grid voltage (V a.c.)	230		
Grid voltage range (V a.c.)	180~280		
Grid type	Single-phase		
Rated output current (A a.c.)	15.6	21.7	26.2
Max. continuous output current (A a.c.)	15.6	21.7	26.2
Max. output over current protection (A a.c.)	41		
Max. output fault current (A a.c.)	41		
Rated grid frequency (Hz)	50/60		
Grid frequency range (Hz)	45.0~55.0		
Power factor (rated power)	>0.99		
Power factor range	0.8 ahead~0.8 lag (0.8* rated power)		
THDi	<3% (rated power) <5% (load is 50%, rated power)		
Backup output			

Item	Model		
	iHome-INV3.6k-H1H01	iHome-INV5k-H1H01	iHome-INV6k-H1H01
Rated output power (VA)	3600	5000	6000
Max. apparent power (VA)	3600	5000	6000
Rated voltage (V a.c.)	230		
Rated output current (A a.c.)	15.6	21.7	26.2
Max. continuous output current (A a.c.)	15.6	21.7	26.2
Max. output over current protection (A a.c.)	23.4	32.6	39.3
BAT input			
Max. input voltage (V d.c.)	500		
Input voltage range (V d.c.)	360~500		
Voltage range with full load (V d.c.)	360-450		
Max. charge current (A d.c.)	25		
Max. discharge current (A d.c.)	25		
BAT pack capacity	5 (5 -40) kwh, voltage range: 360-500 V d.c.		
Max. Batt. short-circuit current (A d.c.)	346		
Max. Batt. backfeed short-circuit current (A d.c.)	9.44		
Protection & Safety			
DC reverse connection protection	Yes		
Anti-islanding Method	Power Variation (Method C)		
Zero-export	Yes		

Item \ Model	iHome-INV3.6k-H1H01	iHome-INV5k-H1H01	iHome-INV6k-H1H01
AC short-circuit protection	Yes		
Leakage current protection (RCD)	Type B		
DRM mode	DRM 0		
DC switch	Yes		
PV fault detect	Yes		
Input DC impedance monitor	Yes		
Surge protection	TYPE II		
Standard & Certification (upon request)	IEC62109-1/-2, EN61000-6-2/-3, EN62109-1/-2, AS/NZS4777.2		
Basic parameter			
Size (W×H×D) (mm)	800×280×233		
Weight (kg)	16.3kg		
Installation	Wall-mounting		
Insulation	No transformer		
Protection grade	IP65		
Self consumption at night	<10W		
Operating temperature range	INV: -25℃~60℃ (3600/5000: If the temperature higher than 45℃ or lower than -25℃, the inverter needs to decrease rated power to use; 6000: If the temperature higher than 40℃ or lower than -25℃, the inverter needs to decrease rated power to use)		
Relative humidity	0~95%		
Cooling	Natural		

Item \ Model	iHome-INV3.6k-H1H01	iHome-INV5k-H1H01	iHome-INV6k-H1H01
Operating altitude	3000m (>3000m derating)		
Noise (typical)	<25db (A) @ 1m		
Display	LED		
Communication	RS485 /WIFI/ /DRM (Australia)		
AC terminal	E10-12 Grid (max.10mm ²) E06-12 Backup (max.6mm ²)		
PV DC terminal	MC4 (max.6 mm ²)		
BAT terminal	MC4 (max.10 mm ²)		
Overvoltage category	II		
Pollution degree	II		

- Specifications are subject to change without prior notice.

B Acronyms and Abbreviations

A

AC Alternating Current

AWG American Wire Gauge

C

CE Conformance Européenne

D

DC Direct Current

E

EPO Emergency Power Off

I

IEC International Electrotechnical Commission

L

LED Light-emitting Diode

M

MPPT Maximum Power Point Tracking

P**PE** Protective Earthing**PV** Photovoltaic**R****RS485** Recommend Standard485**T****THDi** Total Distortion of the input current waveform

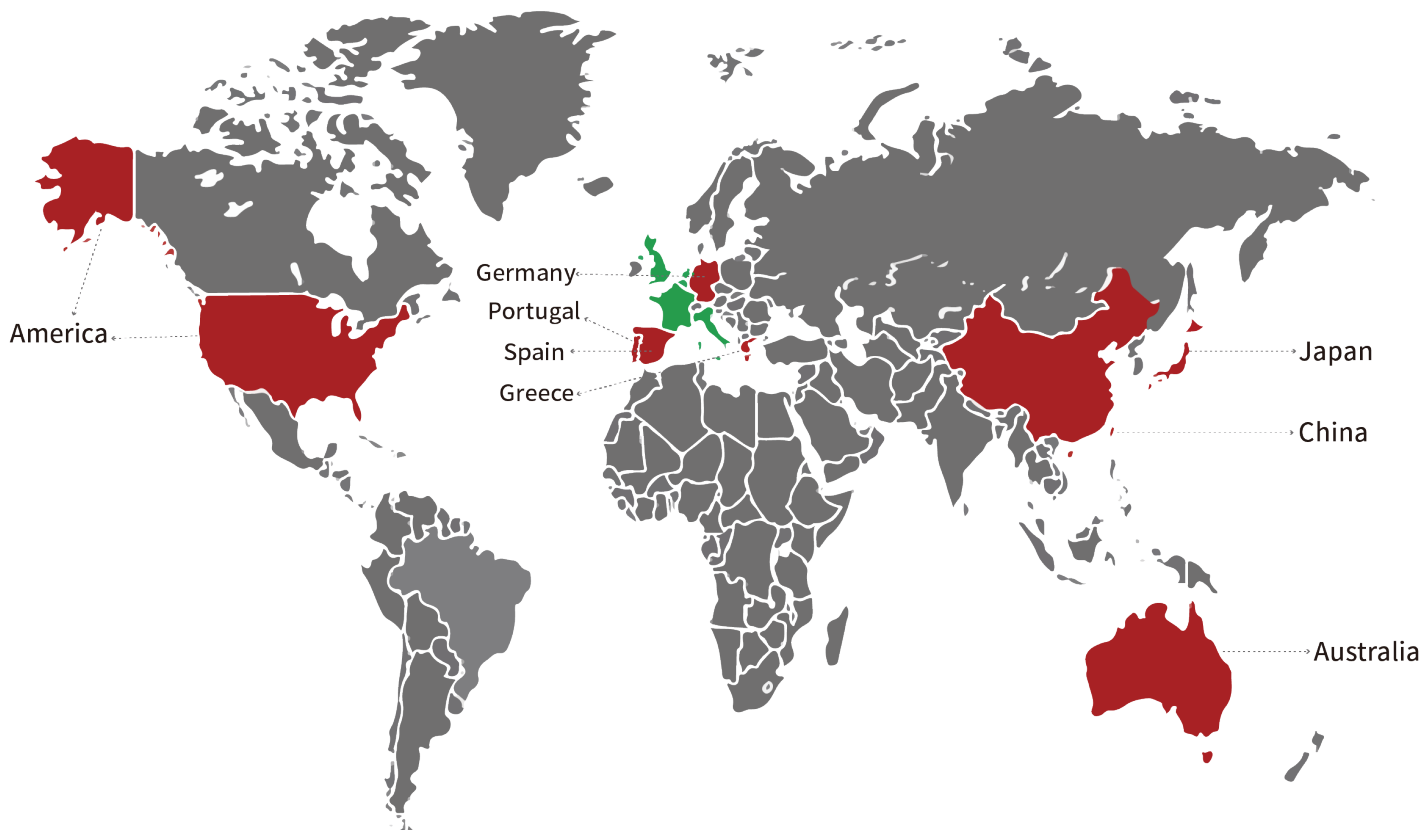

Shanghai Chelion Renewable Technology Co., Ltd.

🏠 Room 2601, Tower A, Dawning Centre, 500 Hongbaoshi Road, Changning District, Shanghai, 201103, China.

✉️ Info.chelion.com

☎️ (21)-62378993

🌐 www.chelion.com

Chelion America LLC.

🏠 4675 Stevens Creek Blvd, Ste250, Santa Clara, CA 95051

✉️ info@chelion.us

☎️ (408)-933-3974

🌐 www.chelion.us

Chelion Australia Pty Ltd.

🏠 L13, 144 Edward St, Brisbane City, QLD 4000, Australia

☎️ 1300 208 962

🌐 www.chelion.com.au

Chelion Japan Co., Ltd.

🏠 27F Shinjuku Square Tower, 6-22-1 NishiShinjuku, Shinjuku-ku, Tokyo, 163-1127, Japan

☎️ 03-6258-1677

🌐 www.chelion.jp

Chelion Iberia, S.L.

🏠 Calle José Echegaray 8, Edificio 3, 1º, 28232, Las Rozas de Madrid (Madrid), España

✉️ info@chelion.eu

☎️ +34 918398560

🌐 www.chelion.eu

Chelion Germany GmbH i.Gr.

🏠 Lurgiallee 10-12, 60439 Frankfurt am Main

☎️ +49 17675312695

✉️ tingting.sun@chelion.com